

**DISTINTA DELLE PARTI COSTITUENTI LE POMPE CENTRIFUGHE AUTOADESCANTI SERIE " J "**  
**SPARE PARTS LIST FOR "J" SERIES SELF-PRIMING PUMPS**  
**LISTE DES PIECES DE RECHANGE POUR POMPES CENTRIFUGES AUTO-AMORCANTES SERIE "J "**  
**ERSATZTEILLISTE FÜR SELBSTANSAUGENDE KREISELPUMPEN SERIE "J "**

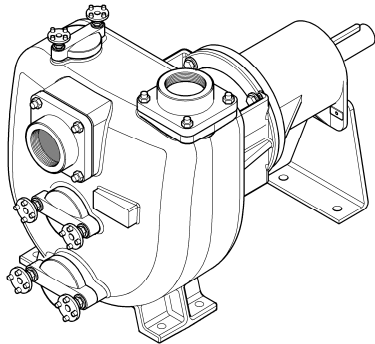

JS 3-252 G10 Code 1004 6093

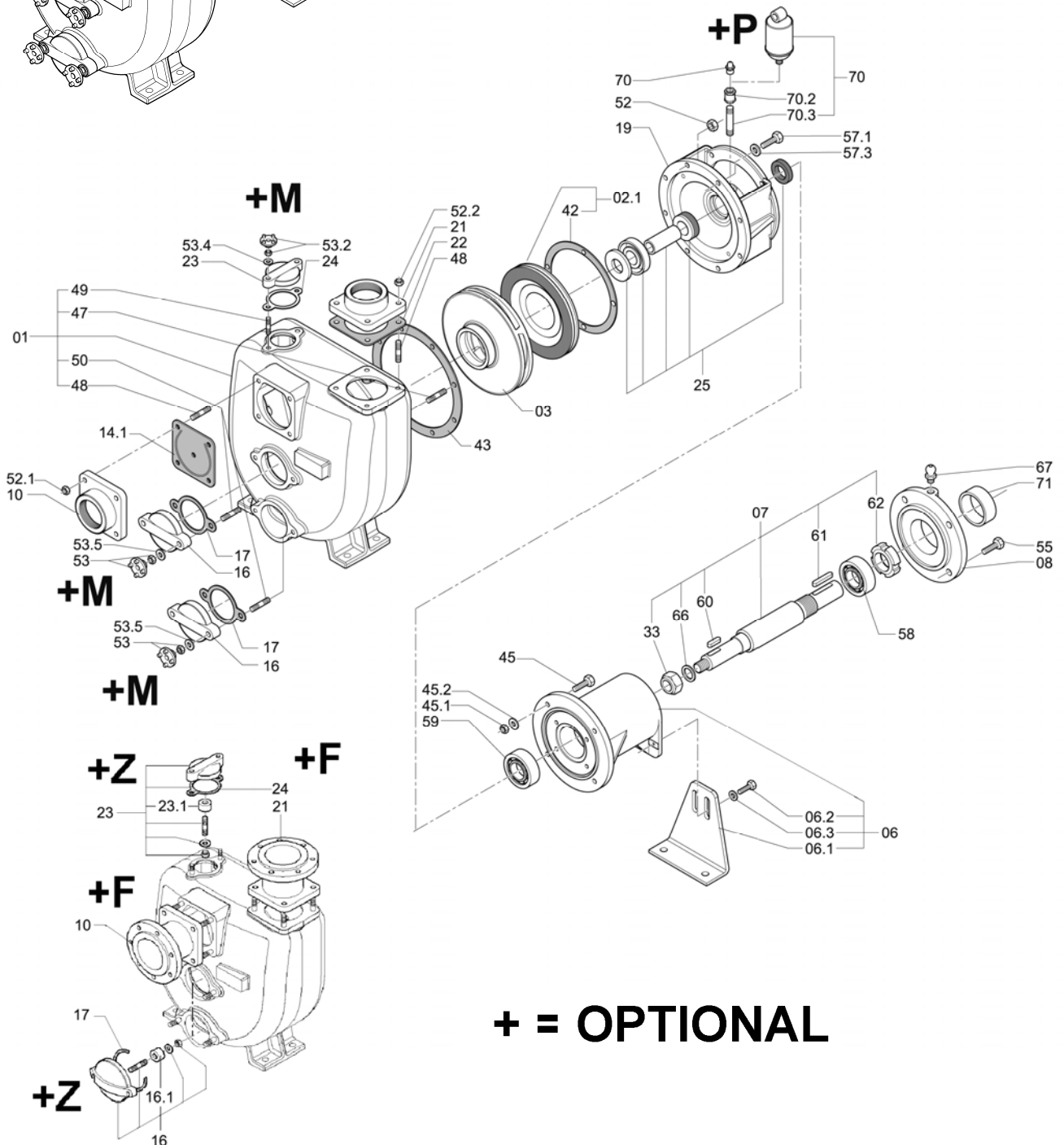

**+ = OPTIONAL**

Rif. N° Pos. Nr.	Quant.	Denominazione	Part name	Den. Comm. Type	Mat. *	Codice Nuovo New Part. No.	JS 3-252 G10
01	1	Corpo (1)	Casing (1)		GS	1004 7392	○
02.1	1	Piatto d' usura (2)	Wear plate (2)		GN	1002 3926	○
03	1	Girante	Impeller		GS	1004 4814	○
06	1	Supporto	Bearing housing		G	1002 1206	○
06.1	1	Piede supporto	Bearing housing foot		S	1002 1223	○
06.2	2	Vite	Screw	M 14 x 30 DIN 933	S	1002 8305	○
06.3	2	Rondella	Washer	M14 UNI 1751/52 A	S	1000 1682	○
07	1	Albero (3)	Shaft (3)		S	1002 1225	○
08	1	Copricuscinetto	Bearing cover		G	1000 4775	○
10	1	Portavalvola	Suction flange	R 3"	G	1000 6422	○ +F
14.1	1	Valvola completa	Check valve ass.		NH	1000 9019	○
16	1	Portina	Cover		G SZ	1000 6474 1000 8503	○ +Z
16.1	2	Placca zinco	Zinc anode		Z	1000 3810	+Z
17 (**)	2	Guarnizione	Gasket				
19	1	Portamotore	Head		G	1002 1216	○
21	1	Flangia mandata	Discharge flange	R 3"	G	1000 5090	○ +F
22 (**)	1	Guarnizione	Gasket				
23	1	Portina	Cover		S SZ	1000 6473 1000 8502	○ +Z
23.1	1	Placca zinco	Zinc anode				+Z
24	1	Guarnizione	Gasket				
25	1	Anello di tenuta	Mechanical seal ass.	T 45 YYN		1002 1228	○
33	1	Dado girante	Impeller nut	M 30 x 2 UNI 7474	H	1000 1466	○
42 (**)	1	Guarnizione piatto	Wear plate gasket				
43 (**)	1	Guarnizione corpo	Casing gasket				
45	4	Vite	Screw	M 12 x 45 DIN 933	S	1000 1963	○
45.1	4	Dado	Nut	M 12 DIN 934	S	1000 1422	○
45.2	4	Rondella	Washer	M 12 UNI1751/52	S	1000 1681	○
47 (*)	8	Prigioniero	Stud	M 12 x 30 DIN 938	S		○
48 (*)	8	Prigioniero	Stud	M 10 x 25 DIN 938	S		○
49 (*)	2	Prigioniero	Stud	M 10 x 30 DIN 938	S		○
50	4	Prigioniero	Stud	M 10 x 30 DIN 938	S		○
52 (*)	8	Dado	Nut	M 12 DIN 934	S		○
52.1(*)	4	Dado	Nut	M 10 DIN 934	S		○
52.2(*)	4	Dado	Nut	M 10 DIN 934	S		○
53 (*)	4	Dado	Nut	M 10 DIN 934	S		○
		Maniglietta	Wrench	M 10	OTS		+M
53.2 (*)	2	Dado	Nut	M 10 DIN 934	S		○
		Maniglietta	Wrench	M 10	OTS		+M
53.4(*)	2	Rondella	Washer	M 10 DIN 125 A	S		○
53.5(*)	2	Rondella	Washer	M 10 DIN 125 A	S		○
55	2	Vite	Screw	M 6x25 DIN 933	S	1002 8349	○

Rif. N° Pos. Nr.	Quant.	Denominazione	Part name	Den. Comm. Type	Mat. *	Codice Nuovo New Part. No.	JS 3-252 G10
57.1(*)	4	Vite	Screw	M 12 x 25 DIN 933	S		○
57.3(*)	4	Rondella	Washer	M 12 UNI1751/52 A	S		○
58	1	Cuscinetto	Ball bearing	3308		1000 1348	○
59	1	Cuscinetto	Ball bearing	62208-2RS		1000 1365	○
60	1	Linguetta	Key	10 x 8 x 40 DIN 6885A	K	1000 1626	○
61	1	Linguetta	Key	10 x 8 x 70 DIN 6885A	S	1000 1598	○
62	1	Ghiera	Sleeve	M 40	S	1000 1573	○
66	1	Rondella	Washer	M 30 DIN 125 A	H	1000 1716	○
67	1	Ingrassatore	Ingrassatore	M 6		1000 1664	○
70	1	Ingrassatore	Ingrassatore	R 1/4"		1000 1662	○
						1000 8316	+P
70.2	1	Manicotto	Union	R 1/4" M/F	S		+P
70.3	1	Prolunga	Grease tube	1/4"	S		+P
71	1	V-ring	V-ring		N	1000 1294	○
( * )		Serie viterie	Set of screw			1004 2644	○
( ** )		Serie guarnizioni	Set of gaskets		N	1004 2645	○
+F ***		Kit flange	Kit flange	DN 80 PN 16	G	1004 2810	○
				3" ASA150	G	1004 2819	○
+P ***		Kit ingrassatore	Compl. Grease kit			1000 8316	○
+Z ***		Kit portine	Set of couver		GZ	1004 7393	○
+M ***		Kit manigliette	Set of wrench		OTS	1004 2794	○
***		Optional					

Note:	Notes:
1) Completo di prigionieri (47, 48, 49, 50).	1) Complete with studs (47, 48, 49,50).
2) Completo di guarnizione (42).	2) Complete with gasket (42).
3) Completo di dado, rondella e linguette (33, 60, 61, 66)	3) Complete with nut, washer and keys (33, 60, 61, 66)
* Materiali di costruzione	* Construction materials
E3 = Centellen VS 3820	E3 = Centellen VS 3820
G = Ghisa	G = Cast iron
GS = Ghisa sferoidale	GS = Ductile cast iron
H = Acciaio inox AISI 304	H = AISI 304 stainless steel
K = Acciaio inox AISI 316	K = AISI 316 stainless steel
N = Nitrile	N = Nitrile rubber
OTS = Ottone	OTS = Brass
S = Acciaio	S = Steel
Z = Zinco	Z = Zinc
Ordinare il materiale indicando sempre la quantità, la denominazione, il codice del pezzo, il tipo e il numero della pompa.	When ordering spares always indicate: quantity, part name and part number, type and serial number of pump.

VARISCO S.p.A.

Terza Strada, 9 - Z.I. Nord - 35129 Padova - Italy

Tel. 049 82 94 111

+39 049 82 94 111

Fax 049 82 94 373

International +39 049 80 76 762



**VARISCO S.p.A.**  
Terza Strada, 9 - Z.I. Nord - 35129 Padova - Italy  
Tel. 049 82 94 111 +39 049 82 94 111  
Fax 049 82 94 373 International +39 049 80 76 762

