

DISTINTA DELLE PARTI COSTITUENTI LE POMPE ROTATIVE VOLUMETRICHE SERIE "V"
SPARE PARTS LIST FOR "V" SERIES POSITIVE-DISPLACEMENT ROTARY PUMPS
LISTE DES PIECES DE RECHANGE POUR POMPES ROTATIVES VOLUMETRIQUES SERIE "V"
ERSATZTEILLISTE FÜR SELBSTANSAUGENDE INNENZAHNRADPUMPEN SERIE "V"

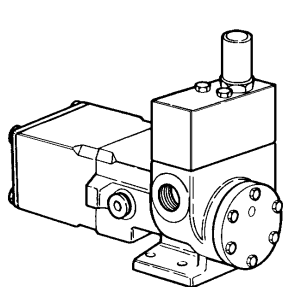

V 12 SPK TN Code 1002 0736
 V 12 ST5K TN Code 1000 9881

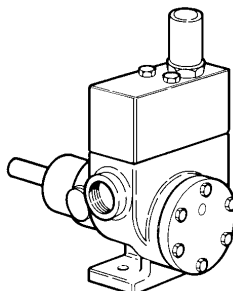

V 12 SPG Code 1000 9873
 V 12 ST6G Code 1000 9876

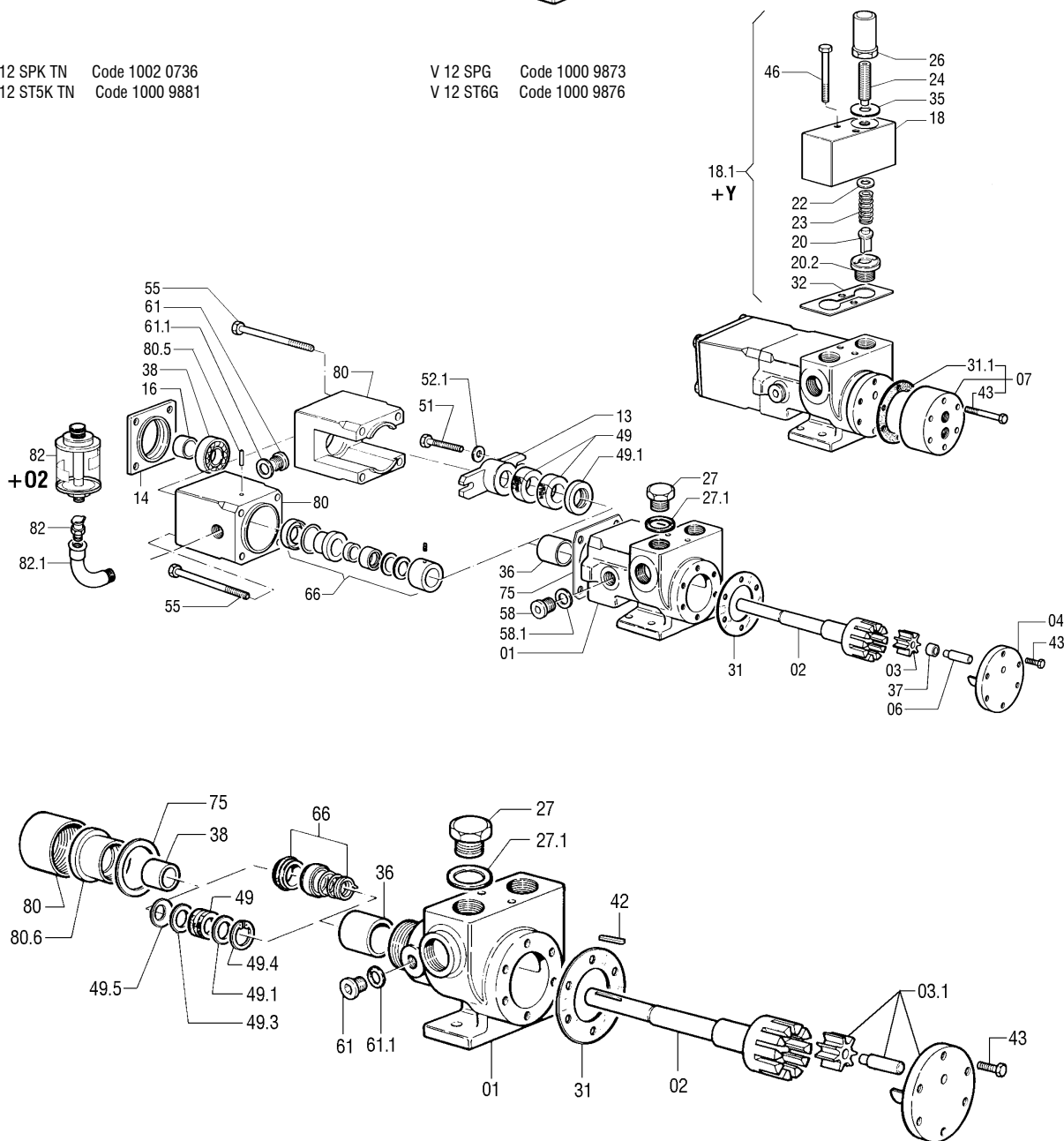

Rif. N° Pos. Nr. Ref. no. Réf. N°	Quant.	Denominazione	Part name	Den. Comm. Type	Mat.*	Codice Vecchio Old Part No.	Codice Nuovo New Part No.	V 12 SPG	V 12 ST6G	V 12 SPK TN	V 12 ST5K TN
01	1	Corpo	Casing		G	3319 3089	1000 4954	○	○		
					K	3319 5060	1000 5023			○	○
02	1	Rotore con albero	Rotor with shaft		S	3765 4032	1000 6644	○	○		
					K	3765 5030	1000 6704			○	○
03	1	Ruota Oziosa	Idler		K	3780 5024	1000 6837			○	○
03.1	1	Kit Coperchio + Ruota Oziosa + Perno	Kit Cover + Idler + Idler Pin				1001 6838	○	○		
04	1	Coperchio	Cover		G	3270 5024	1000 4744			○	○
06	1	Perno	Idler pin	D.6	K5	3540 5066	1000 5951			○	○
07	1	Camera di preriscaldamento (1)	Heating jacket (1)		S	5135 4015	1001 6789	①	①	①	①
13	1	Premitreccia	Gland		K	3690 5011	1000 6529			○	
14	1	Copricuscinetto	Cover		S	3287 7000	1000 4821			○	○
16	1	Ghiera	Sleeve	15 x 24 x 11,5	S	3107 4015	1000 4249			○	○
18	1	Corpo By-pass	By-pass casing		K	3240 5082	1000 4545	②	②	②	②
18.1	1	By-pass	By-pass		K	5090 5023	1000 7768	②	②	②	②
20	1	Valvola By-pass	By-pass check valve		K	3240 5081	1000 4544	②	②	②	②
20.2	1	Sede valvola	Valve seat		K	3240 5080	1000 4543	②	②	②	②
22	1	Piattello By-pass	By-pass plate	M8 DIN 125 A	H	1450 5016	1000 1718	②	②	②	②
23	1	Molla By-pass	By-pass spring	D. 2 x 11 x 33 x 5,5	K	3495 5026	1000 5809	②	②	②	②
24	1	Vite By-pass	By-pass screw		K	3240 5084	1000 4546	②	②	②	②
26	1	Cappello By-pass	By-pass cap		K	3240 5000	1000 4493	②	②	②	②
27 (*)	2	Tappo	Plug	1/2"	S			○	○		
					K					○	○
27.1 (**)	2	Guarnizione	Gasket	1/2"							
31 (**)	3	Guarnizione coperchio	Cover gasket								
31.1	1	Guarnizione coperchio	Cover gasket	39 x 63 x 0,05	TE	3450 0119	1000 5536	①	①	①	①
32	1	Guarnizione by-pass	By-pass gasket		E3	3450 0032	1000 5514	②	②	②	②
35	1	Guarnizione cappello	Cap gasket	13 x 24 x 0,5	E3	3450 0029	1000 5512	②	②	②	②
36	1	Bronzina supporto	Bearing bush	20 x 26 x 26	BS	3120 2071	1000 4323	○	○		
					GR	3120 0068	1000 4294			○	○
37	1	Bronzina ruota oziosa	Idler bush	6 x 10 x 8	GR	3120 0054	1000 4289			○	○
38	1	Bronzina portatenuta	Bush	14 x 18 x 14	BS	3120 2045	1000 4311	○	○		
										○	○
42	1	Linguetta	Key	5 x 5 x 20 DIN 6885 A	S	1434 4005	1000 1585	○	○		
43 (*)	6	Vite	Screw	M 6 x 16 DIN 933	S	1478 4004	1000 1932	○	○		
					K	1478 5001	1000 2022			○	○
					K	1478 5006	1000 2025	①	①		
					S	1478 4008	1000 1935			①	①
46	2	Vite	Screw	M 8 x 60 DIN 931	K	1478 5020	1000 2038	②	②	②	②
49	1	Baderna	Packing	14 x 26 x 6	TE		1002 0587	○			
				22 x 42 x 10			1002 0705			○	
49.1	2	Anello	Ring	25,5 x 15 x 2	H	3045 0003	1000 4050	○			
					K	3045 5116	1000 4136			○	
49.3	1	Anello	Ring	25,5 x 15 x 2	H	3045 0003	1000 4050	○			
49.4	1	Anello seeger	Circlip	D.26 UNI 7437-75	S	1410 4012	1000 1308	○			
49.5	3	Molla reggispira	Spring	25,7 x 14,3 x 0,4	S	1495 4003	1000 2092	○			
51	2	Vite	Screw	M 6 x 25 DIN 933	K	1478 5066	1000 2069			○	
52.1	2	Rondella	Washer	M 6 DIN 125A	K	1450 5015	1000 1717			○	
55	4	Vite	Screw	M 6 x 90 DIN 931	K	1478 5083	1000 2080			○	○
58 (*)	1	Tappo	Plug	1/4" DIN 908	K					○	○
58.1	1	Guarnizione	Gasket	1/4" DIN 908	D	3450 0600	1000 5657			○	○
61 (*)	1	Tappo	Plug	R 1/8" DIN 908	S			○	○		
				1/4" DIN 908	K	1671 5002	1000 2414				○
61.1 (**)	1	Guarnizione	Gasket	1/8" DIN 908							
				1/4" DIN 908	D	3450 0600	1000 5657				○

VARISCO S.p.A.

35129 Padova - Z.I. Nord Terza Strada, 9

Tel. 049 82 94 111

Fax 049 82 94 373

+39 049 82 94 111
International +39 049 80 76 762



Rif. N°. Pos. Nr. Ref. no. Réf. N°.	Quant.	Denominazione	Part name	Den. Comm. Type	Mat.*	Codice Vecchio Old Part No.	Codice Nuovo New Part No.	V 12 SPG	V 12 ST6G	V 12 SPK TN	V 12 ST5K TN
66	1	Tenuta completa	Mechanical seal	N 14 HGV		5917 0074	1000 8849		○		
				N 22 GCT - FL		5919 4000	1000 8940				○
75 (**)	1	Guarnizione	Gasket	26,5 x 32 x 0,5							
80	1	Portatenuta	Seal box		S	3615 4303	1000 6197	○	○		
					K	3615 5350	1000 6236				○
		Portabaderna	Stuffing Box		K	3615 5012	1000 6209			○	
80.5	1	Spina	Spring pin	3 x 20	K	1463 5008	1000 1785				○
80.6	1	Bussola portatenuta	Seal box		S	3107 4012	1000 4234	○	○	○	
82	1	Oliatore	Oil lubricator	R ¼" KLG4		1444 0053	1000 1671				○
				R ¼"		1444 0055	1000 1672				③
82.1	1	Curva	Elbow	MF ¼"	S	1601 3002	1000 2292				○
(*)		Serie viterie	Set of screws				1001 5189	○	○		
							1001 5192			○	○
(**)		Serie guarnizioni	Set of gaskets				1001 4958	○	○		
							1001 4961			○	○

Note:

1) Completo di guarnizione (31.1) e vite (43).

- ① +R2 Con camera di preriscaldamento.
- ② +Y Con by-pass.
- ③ +O2 Con oliatore 0,2 l in vetro.

* Materiali di costruzione

B	=	Bronzo
D	=	Guarnital
E3	=	Centellen VS 3820
G	=	Ghisa
GR	=	Grafite
H	=	Acciaio INOX AISI 304
K	=	Acciaio INOX AISI 316
K5	=	Acciaio inox AISI 329
S	=	Acciaio
T3	=	Acciaio K100
TE	=	Teflon

Ordinare il materiale indicando sempre la quantità, la denominazione, il codice del pezzo, il tipo ed il numero della pompa.

Notes:

1) Complete with gasket (31.1) and screw (43).

- ① +R2 Heating jacket on cover.
- ② +Y With by-pass.
- ③ +O2 With 0,2 l glass lubricator.

* Construction materials

B	=	Bronze
D	=	Guarnital
E3	=	Centellen VS 3820
G	=	Cast iron
GR	=	Graphite
H	=	AISI 304 stainless steel
K	=	AISI 316 stainless steel
K5	=	AISI 329 stainless steel
S	=	Steel
T3	=	K100 steel
TE	=	Teflon

When ordering spares always indicate type and serial number of pump, quantity, part name, and number.

VARISCO S.p.A.

35129 Padova – Z.I. Nord Terza Strada, 9

Tel. 049 82 94 111

+39 049 82 94 111

Fax 049 82 94 373

International +39 049 80 76 762



VARISCO S.p.A.

35129 Padova – Z.I. Nord Terza Strada, 9

Tel. 049 82 94 111

+39 049 82 94 111

Fax 049 82 94 373

International +39 049 80 76 762

