

ROTAIR *S.p.A.*

MANUALE DI USO E MANUTENZIONE - RICAMBI
MANUEL D'ENTRETIEN - PIECES DE RECHANGE
OPERATING MAINTENANCE - PARTS MANUAL
BEDIENUNG UND WARTUNGSANLEITUNGEN
MANUAL DE USO Y MANTENIMIENTO - RECAMBIOS

MOBILE MOTOR COMPRESSOR

MDVN

36 AP

SUBJECT INDEX

- 1) **Identification data** _
- 2) **Technical data** _
- 3) **Manual use and consultation** _
- 4) **Envisaged machine use** _
- 5) **Technical description of machine and its function** _
 - 5.1) **Chassis and axle** _
 - 5.2) **Bodywork** _
 - 5.3) **Motor** _
 - 5.4) **Compression unit** _
 - 5.5) **Oil separator tank** _
 - 5.6) **Bell and flexible coupling** _
 - 5.7) **Control instruments and devices** _
 - 5.8) **Wiring system and its function** _
 - 5.8.1) **Safety devices** _
 - 5.9) **Oleopneumatic plant and its function** _
 - 5.9.1) **Lubrication circuit** _
 - 5.9.2) **Pneumatic circuit** _
 - 5.9.3) **Automatic regulation of the motor speed** _
- 6) **Machine handling and parking** _
 - 6.1) **Lifting instructions** _
 - 6.2) **Towing instructions** _
 - 6.3) **Transport instructions** _
 - 6.4) **Parking instructions** _
- 7) **Instructions for machine use** _
 - 7.1) **Before starting the machine. Check the motor and compressor oil levels** _
 - 7.2) **Starting up** _
 - 7.3) **During the working stage** _
 - 7.4) **Stopping** _
 - 7.5) **After machine stop** _
- 8) **Machine setting and tuning** _
 - 8.1) **Checking and setting of motor speeds** _
 - 8.2) **Checking and setting of maximum final pressure** _
 - 8.3) **Checking and setting of minimum pressure** _
 - 8.4) **Safety valve check** _
- 9) **Maintenance programme** _
 - 9.1) **Daily checks** _
 - 9.2) **Weekly checks** _
 - 9.3) **Three-monthly checks** _
 - 9.4) **Annual checks or when total number of hours is reached** _
- 10) **Periodic maintenance** _
 - 10.1) **Checking and cleaning of air suction filter** _
 - 10.2) **Battery check** _
 - 10.3) **Tyre pressure check** _
 - 10.4) **Cooling radiator cleaning** _
 - 10.5) **Checking and cleaning of the oil recovery nozzle** _
 - 10.6) **Fuel tank drainage** _
 - 10.7) **Braking device check** _
 - 10.8) **Wheel screw checking** _
 - 10.9) **Compressor oil filter replacement** _
 - 10.10) **Compressor oil replacement** _
 - 10.11) **Checking and replacement of the oil separator element** _
- 11) **Problems : causes and remedies** _
- 12) **Spares** _

-- 1) IDENTIFICATION DATA --

Here follows details of the information printed on the machine identification plate situated at the front of the machine.

MODEL:	MDVN 36 AP
REGISTRATION NO.:	
MASS (Kg):	698
AIR DELIVERY (litres per minute) * :	3600
WORKING PRESSURE (bar):	7
YEAR OF CONSTRUCTION:	
ACOUSTIC POWER dB(A) ** :	< 100

(*)Measured in accordance with ISO 1217 standards ($\pm 5\%$).

(**)Measured in accordance with directive CEE 84/533, technical adaptation 85/406/CEE.



CAUTION:

The use of non-original ROTAIR spares will result in the immediate cancellation of the guarantee.

On requesting assistance or ordering of parts always cite the model number and registration number above.

-- 2) TECHNICAL DATA --

COMPRESSOR:

-- WORKING PRESSURE:	7 bar
-- MAXIMUM FINAL PRESSURE:	8,25 bar
-- MINIMUM WORKING PRESSURE:	5 bar
-- MAX. ROTATION SPEED.:	3000 r.p.m.
-- AIR YIELD AT MAX SPEED AND ON WORKING PRESSURE:	3600 litres/1'
-- COOLING:	hydraulic oil (*)
-- OIL SYSTEM CAPACITY:	7 litres

(*) SHELL CORENA D is recommended.

Corresponding types allowed:	VERETRUM 46	IP.
	DICREA 46	AGIP.
	SCHUMANN 46	Q8.
	RASUS 424	MOBIL.
	RASUS 425	MOBIL.
	AIRCOL PD 32	CASTROL.

MOTOR:

-- MODEL:	PERKINS 403-C15
-- NUMBER OF CYLINDERS:	3
-- DISPLACEMENT:	1500 cm ³
-- AVAILABLE POWER:	25,2 KW (34,2 HP)
-- COOLING:	liquid type
-- MAX. ROTATION SPEED:	2900 r.p.m.
-- MIN. ROTATION SPEED:	1900 r.p.m.
-- ELECTRICAL SYSTEM TENSION:	12 Volt

For all other information, regarding the motor, consult the use and maintenance booklet of the manufacturer itself, enclosed with this documentation.

COMPLETE MACHINE:

-- MAX. ENVIRONMENTAL TEMPERATURE:	40 °C
-- LENGTH (excluding drawbar):	1692 mm
-- WIDTH:	1340 mm
-- HEIGHT:	1300 mm
-- WEIGHT IN WORKING CONDITION (approximate):	698 Kg
-- TYRE TYPE:	145/80 R13

-- 3) THE PURPOSE OF THE MANUAL AND WHO IT IS TO BE CONSULTED BY -

The owner, user and maintenance technician must carefully study the manual to ensure that it is used for the purposes for which it has been designed and constructed.

It is essential that all the information contained in this manual are applied, in order to ensure optimum use of the machine under the safest conditions.

This manual fully describes:

- the information concerning the drawing, lifting and parking of the machine;
 - the general standards and useful advice for both ordinary and special maintenance;
 - the means for the identification and ordering of spares.
- NB: The instructions for correct motor use are provided by the motor manufacturer itself.

The correct and careful use of the machine in accordance with the instructions contained in this manual, will ensure the long life of the machine, and will also enable the personnel to prevent the risk of any accidents or injury during work.

This manual must be carefully conserved, in its special case, away from any humidity, heat and sun's rays, to ensure that it is ready for consultation at any time, both by the operational personnel and the maintenance staff.

It is important to ensure that the special maintenance operations in particular are undertaken by specialized personnel.

In the event of loss or damage of this manual, ROTAIR must be asked for a copy, citing the relative machine identification details as shown on the plate on the machine.

Should the plate become illegible, use the details quoted on the invoice on requesting a new manual.

Further information or instructions for use or relating to any further interventions necessary on the machine can be request ROTAIR SPA directly, always citing the machine identification details.

This machine has been exclusively designed and **built to supply compressed air** in the conditions as envisaged by the manufacturer. Any other use not envisaged in this description will be considered as being "*non conforming*" and will release the manufacturer from any further responsibility which will fully that of the user itself.

"*Conforming use*" presupposes the observance of the following regulations concerning the use, maintenance and transport of the unit itself.

It is also necessary to ensure that all the accident prevention regulations hereby described are followed, also in accordance with general safety regulations as indicated in the current legislation.

The constructor declines any responsibility in the event of any modifications made to the machine without its authorization.

The machine is supplied complete with the following documents:

- 1) - General use and maintenance booklet;
- 2) - Motor use and maintenance booklet;
- 3) - Declaration of machine conformity to the R.E.S. of EEC directive 89/392;
- 4) - Conformity certificate of the oil separator tank;
- 5) - Certificate of homologation for road circulation (should this have been envisaged and requested in the sales contract);
- 6) - Instructions booklet for the axle and the drawbar;
- 7) - Certificate of conformity of the safety valves of the oil separator tank;
- 8) - Motor guarantee certificate;
- 9) - Compressor guarantee certificate.

-- 4) ENVISAGED MACHINE USE --

The **MDVN** motor-driven compressor is a machine which generated a well-defined quantity of compressed air measures in litres per minute.

There are many field of application for the use of all those tools, accessories and implements which have a "**pneumatic**" function such as demolition hammers, perforation hammers, vibrators, drills, starters, compactors, plasterers, etc...

Each instrument has a compressed air consumption measured in litres per minute.

The best ratio between compressor and tool is when the compressed air consumption of this last does not exceed 85% of the air generated by the compressor (also bear in mind that the quantity of compressed air requested by the tool, will increase in proportion to the wear of the tool itself).

A correct compressor-tool ratio will ensure that the machine operates efficiently and will guarantee maximum performance.

If the tool is too big it will jeopardize the correct function of the machine, and its performance will be impaired, not having the necessary amount of compressed air.

This machine has been designed to work at an environmental temperature of between **-10** and **+40°C**.

COUNTER-INDICATIONS

The compressed air generated by this unit contains minute traces of oil and it is therefore not suited to use in those systems that require totally oil-free air (i.e. food industry, pharmaceutical industry, flour and powder transport, etc...).

PRECAUTIONS

GENERAL PRECAUTIONS

1. The machine owner is responsible for ensuring that the compressor is maintained in such conditions as to ensure totally safe operation. Any parts or accessories which fail to guarantee safe function are to be replaced.
2. Use only the oils and lubricants recommended or approved by *ROTAIR S.p.A.* and the engine manufacturer. Ensure that the selected lubricants comply with all current safety provisions, particularly as regards explosion or fire risks, and the hazard of the decomposition or production of harmful gases.
3. The supervisor or the responsible party must ensure that all the instructions concerning the function and maintenance of both machinery and equipment are always carefully followed, and that the machines and all the related accessories and safety instruments, comprising the entire compressed or vacuum air system together with all the related piping, valves, connectors and hoses as well as the expendable elements are in good conditions, that they are not excessively worn and that they are not mishandled.
4. All maintenance, overhauling and repair operations are to be undertaken exclusively by adequately trained staff, and supervised by a person qualified in these types of operations if necessary.
5. In the event of suspected or evident overheating of an internal machine component it is necessary to stop the machine, but do not open any inspection hatch before the necessary cooling time has elapsed, to prevent the risk of the spontaneous combustion of oil vapours on contact with incoming air.
6. Maintenance operations which do not form part of the standard maintenance program, can only be undertaken with the machine at a complete standstill.
7. Before proceeding to disassemble any pressurized component, the compressor, or the machine needs to be suitably isolated from all pressure sources and should be totally exposed to the atmosphere. Each isolation valve must display a warning sign with the wording "work in progress: do not open".
8. Before proceeding with repair work it is necessary to take all the necessary precautions to prevent the risk of sudden starting up. All the starter instruments must also bear a sign with the following wording "work in progress. Do not start up". The battery should be detached and removed or the terminals should be covered with insulating caps.
9. Never allow the machine or appliance to operate at beyond the established limits (in terms of pressure, temperature, speed, etc..)
10. The machines and pneumatic appliances are to be kept clean , and free of oil, dust, or other accumulated dirt.
11. To avoid the risk of the building up of excessive working temperatures, the heat transfer surfaces must be regularly inspected and cleaned (including cooling fins, coolers and the water jackets, etc). A suitable programmed cleaning frequency should be established for each machine.
12. All the regulation and safety instruments must be maintained with the greatest care to ensure their correct function and they must not be placed out of use.
13. Beware of damaging the safety valves and other pressure discharging instruments, obstruction by means of varnish, oil residue or accumulated dirt is to be avoided as it may effect the working efficiency of the instrument.

14. The precision of the pressure and temperature indicators should be regularly checked in order to ensure rapid replacement should the tolerance values be irregular.
15. The parts should be replaced solely using original *ROTAIR S.p.A.* spares.
16. The safety instruments are to be tested as described in the maintenance table in the instructions manual in order to ensure that they are in good operating conditions.
17. Never use any inflammable solvents or carbon tetrachloride to clean the parts. Take the necessary precautions to protect against toxic vapours when cleaning using specific chemical products.
18. Always pay the greatest care to cleanliness in all the maintenance and repair operations. Always protect against dirt by covering the parts and exposed openings with a clean cloth, paper or adhesive tape.
19. Protect the engine, alternator, air intake filter as well as the regulation and electrical components etc to prevent the risk of humidity seeping in, for example during steam cleaning operations.
20. During operations involving either heat, flames or sparks in a machine, the surrounding components must be protected with non-inflammable material.
21. Never use a live flame luminous source to inspect the inside of a machine, pressure container etc.
22. In the case of transportable elements, support the tow bar and axles in a secure manner, should it be necessary to work under the machine or on wheel removal. Do not rely solely on the jacks.
23. Before dismantling a compressor, engine or other machine or before beginning an overhaul operation, avoid moving mobile parts weighting over 15 kg.
24. Once the repairs are complete ensure that no tools, cloths or components have been left inside or on top of the machine, engine or drive elements.

PRECAUTIONS DURING USE AND FUNCTION

Before lifting a unit, all the loose or rotating parts must be firmly secured. Do not apply any cables, chains or ropes directly to the lifting eyebolt, but apply a crane hook or a lifting shackle in compliance with local regulations.

The use of a lifting eyebolt for lifting by means of helicopter is prohibited.

Remaining in a risk zone beneath a raised load is severely prohibited.

All lifting acceleration and deceleration movements must be kept to within safety limits.

1. Before towing the compressor:
 - ensure that the tank has been depressurised;
 - check the tow-bar, the braking system and the towing hook. Also check the hitching system of the towing vehicle.
 - Check that the pivoting wheel and the parking pin are locked into raised position;
 - Ensure that the towing eyebolt is free to rotate around the hook;
 - Check that the wheel nuts are fully tightened and that the tyres are in good condition and at the right pressure;
 - Connect the headlight cable and check all the lights;
 - Remove the wedges that block the wheels, if they have been applied and release the parking brake.
2. Never exceed the maximum compressor towing speed.

3. Position the unit on flat ground and lock the parking brake before releasing the unit from the towing vehicle. Should the compressor not feature a parking brake, immobilise the compressor by placing some wedges in front or behind the wheels.
4. The operator should avoid getting in the way of any released compressed air as the force of the air speed may cause injury to those directly in its path. Never direct the air jet directly onto your own body or anybody else. Never use compressed air to dry your garments.
5. Should it be used for cleaning equipment, proceed with extreme caution using protective goggles.
6. Should the machine need to operate in closed environments, it is necessary to convey the exhaust gas to the exterior using a special duct pipe (a stainless steel spiral pipe is recommended with a diameter of at least 60 mm, the length of which should be as short as possible. It is also necessary when working in closed environments to create a ventilation system that conveys the any dirty, hot or dust saturated air externally, to ensure that the machine can take in air that is fresh and clean.
7. However the operation of the machine in any closed environments with atmospheric conditions in which it is possible to find corrosive or explosive gas vapours or mixtures is **severely prohibited**.
8. When operating in open areas it is necessary to position the machine in such a way as to ensure that on exit of the discharge gas it occurs on the lee side and never in the direction of walls or other obstacles, which might oppose the exit and the dispersion of such exhaust gases.
9. When undertaking any demolition, drilling or sandblasting operations or any similar operations that tend to generate dust, the tool needs to be connected to the compressor used a flexible hose that is pressure resistant and of sufficient length to permit the machine to be distanced from the working area, thereby avoiding the risk of any clogging of either the suction filters on the unit or of the cooling radiator used to cool lubricant and coolant liquids. Once again the operator should ensure that the machine is positioned leeward in relation to the working area.
10. The machine has been designed and constructed to work with bonnet lowered and therefore it **must not** be kept raised with the engine running, because as well as generating high noise levels which are harmful it would also jeopardize the necessary internal ventilation that is essential to ensure correct compressor function.
11. Position the machine away from the walls and take all the necessary precautions to ensure that the hot air discharged from the engine and from the cooling systems is not recycled. Should it be conveyed back into the engine or ventilator there is a risk of machine overheating.
12. When selecting flexible hosing to connect the machine to the tool, it is important to ensure that they are of the correct dimensions, in terms of length, the air volume involved and the working pressure. In fact if the piping is too small in diameter or of excessive length, there is a risk of blocking the air flow, with a loss in charge and reduced tool performance. Never use worn, damaged or faulty hoses.
13. The hosing used to convey the compressed air from the machine to the tool, or to any other appliance that may be applied, must have a cock at one end of the hose connection, this cock should be kept closed when connecting the hosing to the tool and the machine in order to prevent the risk of accidental opening of the cock itself with the consequent risk of severe wobbling of the hosing itself, and even a risk of

-- 5) TECHNICAL DESCRIPTION --

This unit, like the entire MDVN range is an oil injection screw mobile motorized compressor, single-stage and silenced.

The motor is of internal combustion type, and runs on gas oil, and transmits power to the compressor by means of an elastic joint positioned co-axially between the two.

-- 5.1) CHASSIS AND AXLE --

The chassis is made from contoured and electrowelded metal sheet and is of load-bearing type. This chassis undergoes two painting treatments which guarantee corrosion resistance and rust-proofing.

In the chassis there is the control panel which is protected by a transparent polycarbonate lid and which allows the compressed air pressure and the compressor oil temperature values to be read and allows a visual control of the warning lights each of which will indicate any anomalies of the machine element to which it is connected.

A sprung axle of large dimensions supports the machine weight. It also has a drawbar which can be fitted with hook and eyelet or sphere type. It consists of articulated elements which permit correct attachment to the various pulling means.

To tow the motor-driven compressor on the road it must be of homologated version fitted for towing complete with lighting system, headlights and licence plate, braking system and relative authorization from the "Motorization" department.

The braking system includes the parking brake and the inertia braking system. Both act on the wheel-carrier drums of the axle.

-- 5.2) BODY --

The body is built entirely out of galvanized sheet iron. It can easily be turned over thanks to a gas hoist and thus allows convenient access to the main machine elements. The whole machine is entirely lined with sound absorbent and fire-retardant material.

Special holes have been created in the elements forming the body, complete with baffles, which allow the cool air necessary for engine and compressor cooling to be sucked in from one side and the heated air to be expelled from the other side. These baffles have been carefully designed in terms of size and shape so as to allow the most efficient internal ventilation of the machine: it is advisable, therefore, to make sure that these openings are kept free and undamaged.

All the parts of the body have been treated with a special painting process which guarantees excellent finishing quality together with maximum impact and rust resistance.

-- 5.3) MOTOR --

The unit is equipped with a Diesel motor, the features of which are described in paragraph 2 (*Technical data*).

Consult the use and maintenance instructions and the manual supplied by the manufacturing company and enclosed with this documentation.

-- 5.4) COMPRESSION UNIT --

It is completely manufactured in the ROTAIR factory and consists of a central body (cylinder) inside which are fitted two screw rotors with asymmetric section, a male one with 5 lobes and female one with 6 lobes.

The cylinder is closed at the ends by two head sections which contain the bearings which bear the radial and axial loads created by the air compression.

A series of channels, inside the cylinder and heads, undertake to deliver the oil to the various components. The distribution of the lubricant, serves to lubricate the bearings and to maintain a coating of oil between the rotors and the bearings themselves as well as the internal cylinder walls, thereby promoting compression resistance. Another important function of the oil injected between the rotors is that of absorbing the heat generated by the air compression.

The compressed air supplied by this compressor is free of any pulsations and compression comes about axially.

A "regulator" unit is mounted on the compression unit, the purpose of which is to regulate the quantity of air taken in according to the amount of air consumed. A double-stage filter mounted on the top of this unit guarantees maximum purity of the suctioned air.

-- 5.5) OIL SEPARATOR TANK --

Consists of a pressurized container, and due to its construction features it is exempt from the annual I.S.P.E.L. inspection and is supplied with a conformity certificate issued by the manufacturer. The identification and inspection details are impressed on a plate which is welded to the machine.

The lid features the following elements: safety valve for overpressure, a thermal switch which intervenes if the temperature inside the tank exceeds 100°C and valves which regulate the maximum and minimum pressure of the machine.

-- 5.6) BELL AND FLEXIBLE COUPLING --

The engine and the compressor are interconnected by a bell which guarantees concentricity between the engine flywheel and the compressor shaft.

A large-size block joint with rubber pieces interspaced transmits power in a smooth and silent way without splitting.

The engine-compressor thus assembled is clamped to the frame with four flexible supports (silent-blocks) which completely absorb the vibrations it generates. A fan is splined to the engine shaft on the opposite side to the flywheel which generates large air displacement which cools the machine fluids and elements.

-- 5.7) CONTROL INSTRUMENTATION AND DEVICES (FIG.1 --

The control panel layout, near the air exit cocks was specifically designed so as to have all the controls within reach of a single person.

All the necessary instruments to control the unit are located on the control panel.

Figure 1 shows and identifies the various control and command devices.

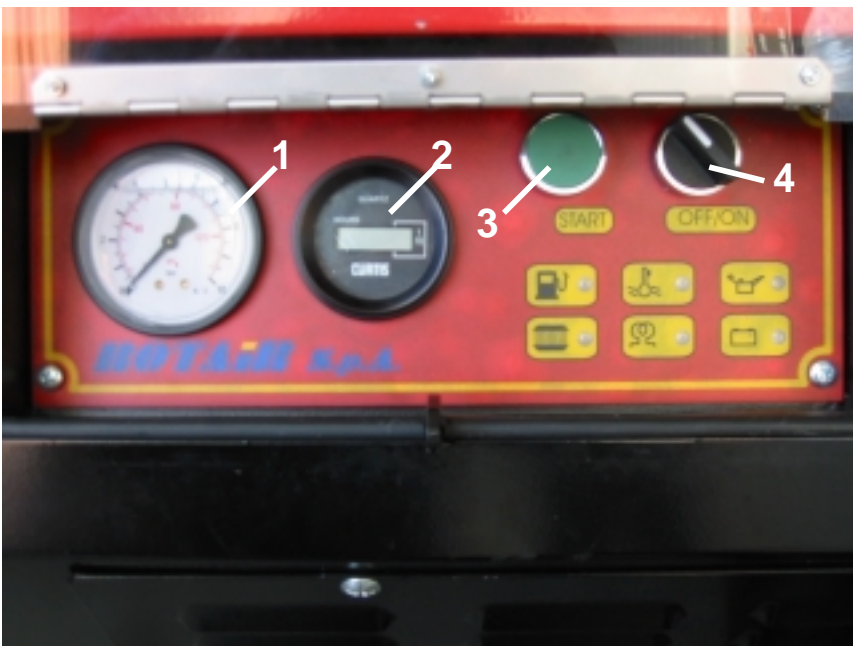

Fig. 1



Fuel level warning light



Glow plugs preheating warning light



Air filter obstruction warning light



Engine oil pressure warning light

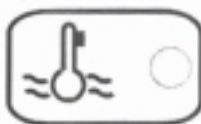

High temperature warning light



Alternator warning light

-- 5.8 WIRING SYSTEM AND ITS FUNCTION --

This motor-driven compressor is fitted with a 12V wiring system with continuous current: the wiring diagram is as follow (table 1):

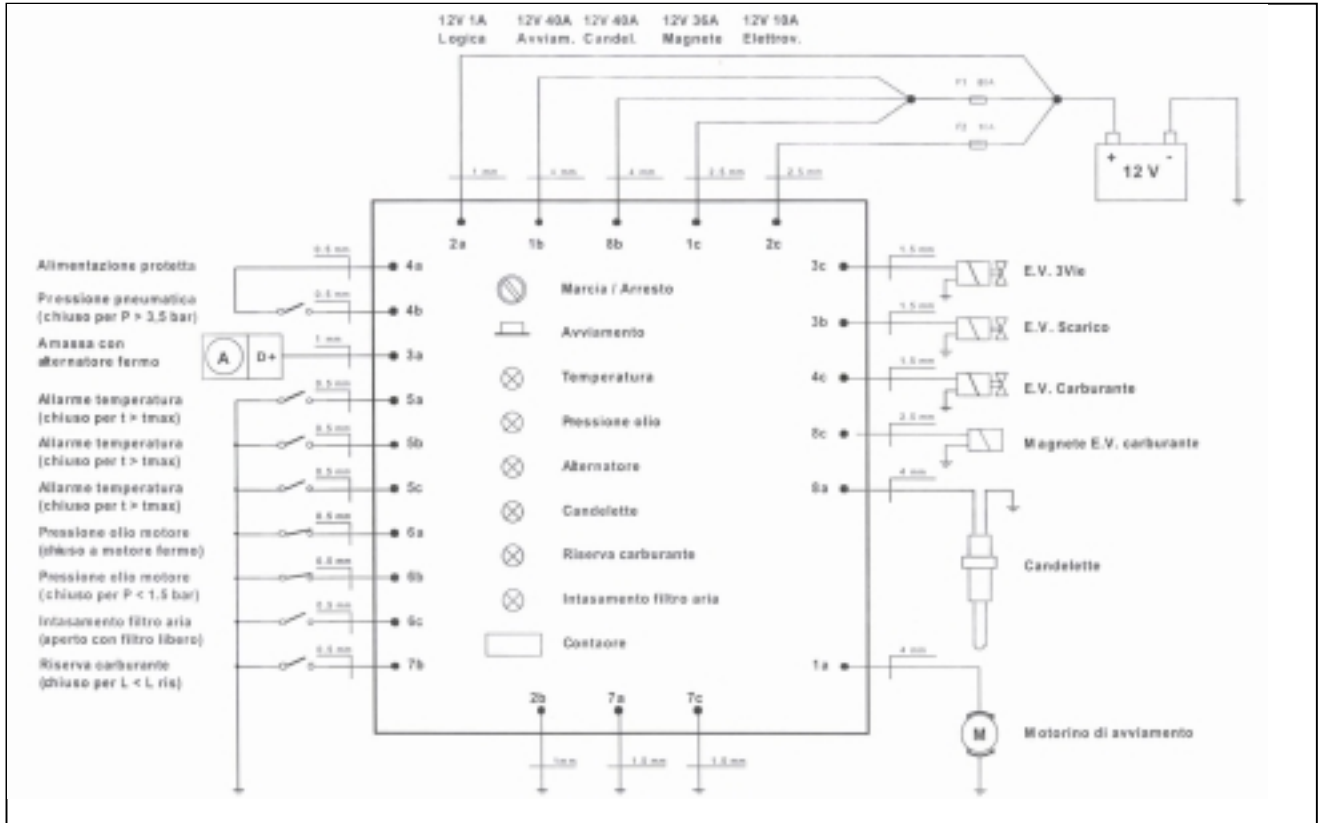

Table 1

<i>Details wiring diagram</i>					
1a	Starter motor	4b	Low pressure stop bulb (3,5bar)	7c	Mass
1b	ignition	4c	Fuel solenoid (hold)	8a	Spark plugs
1c	Magnet feed	5a	Temperature alarm	8b	Spark plug feed
2a	Feed	5b	Temperature alarm	8c	Fuel solenoid (pull)
2b	Mass	5c	Temperature alarm		
2c	Solenoid feed	6a	Motor oil pressure (NC)		
3a	Alternator	6b	Minimum pressure bulb (1,5bar)		
3b	Discharge solenoid	6c	Air filter clogging sensor		
3c	3-way solenoid	7a	Mass		
4a	Low pressure stop bulb (3,5bar)	7b	Gas oil tank float		

The dimensions of all the electrical system components have been designed specially by the manufacturing company; The system on the machine is protected with sheathing of suitable electrical and mechanical characteristics and with high resistance to chemical agents. Automotive fuses of adequate capacity are used to protect against overloading.



CAUTION: All operations on the wiring system must be carried out by specialized personnel.

1) WIRING SYSTEM FUNCTION

1.1) By turning the starting block key (part. 4 fig. 1) to the right in the position "ON", the panel is powered and the following warning lights come on:

Engine oil pressure warning light

This indicates whether the engine oil circuit is in pressure (warning light off) or not (warning light on).

Alternator warning light

This indicates alternator efficiency.

Glow plug warning light

The first two warning lights are red and when the engine has been started they must be off.

The glow plug warning light stays on for as long as it takes to heat the glow plugs after which it switches itself off automatically. At this point it is possible to start the engine-compressor by the push button (part 3 fig 1).

1.2) The starter motor is powered by the push-button which will start the diesel engine.



ATTENTION: *as soon as the diesel engine has started, release the push-button immediately.*

2) By turning the *starting block key (4)* to the left in the "OFF" position the pressure in the tank lowers up to 3-3,5bar.

As soon as the pressure reaches 3-3,5bar the engine automatically stops.

2) In machines approved for road use the electrical system is completed by lighting wiring (TABLE 2). In the table, the wire connections inside the 7-pole socket are given and their connection to the rear light apparatus. This system is connected directly to the towing machine via an extension lead which is supplied with the engine-compressor.



ATTENTION: Always ensure that the electrical system of the towing machine is compatible with the engine-compressor light system (12V d.c.).

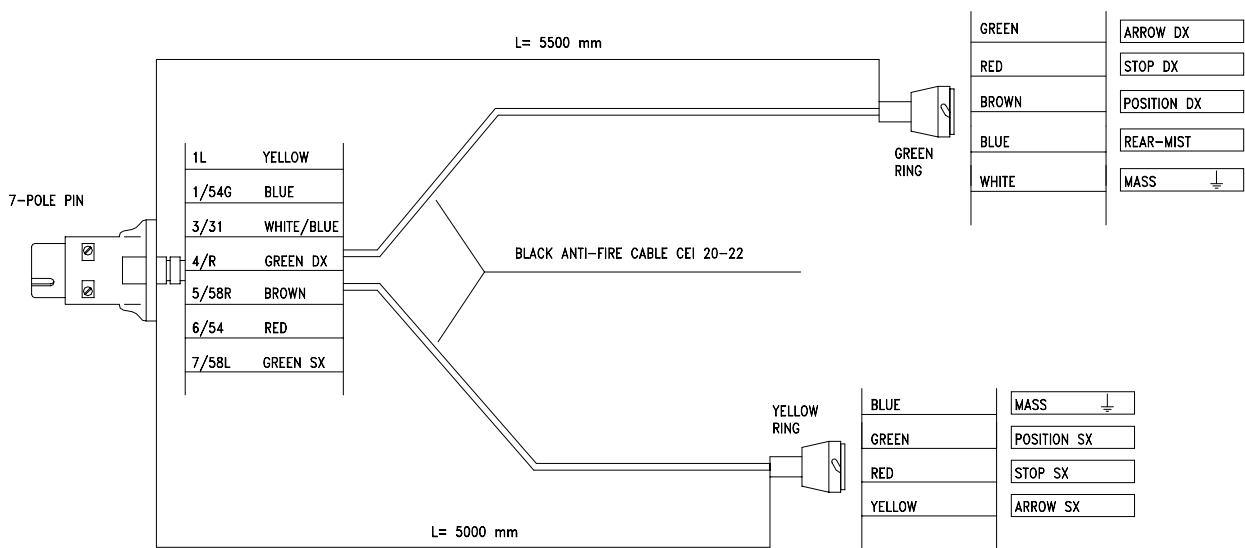

Table 2

-- 5.8.1) SAFETY DEVICES --

These devices protect the machine from all malfunctions which could cause serious damage to the machine, if they are not promptly eliminated.

- **6b** Minimum oil pressure gauge: This device prevents the starting up if the machine until the pressure inside the oil separator tank has not fallen to under **1.5 Bar**. This device consists of a pressure gauge which cutting off power to the starter motor.
- **6a** Motor oil pressure gauge: N.C Contact device, which intervenes in the event of insufficient pressure in the motor oil circuit. It de-energizes the gas oil solenoid valve and discharge solenoid valve causing the motor to come to an immediate stop. The engine oil pressure warning light comes on, indicating the anomaly.
- **5a** Oil separator tank thermal contact: N.O. contact device which protects the oil separator tank from temperatures of over 100°C. This de-energizes the solenoid valves immediately stopping the motor. The high temperature warning light comes on indicating the anomaly.
- **5b** Thermocontact on compressor: N.O. contact device, which intervenes in the event of the overheating of the interior of the compressor which de-energizes solenoid valves immediately stopping the motor. High temperature warning light comes on indicating the anomaly.
- **5c** Thermocontact on motor head: N.O. contact device which intervenes in the event of motor over-heating. This de-energize solenoid valves which immediately stops the motor. The high temperature warning light comes on indicating the anomaly.
- **F1** Spark plug fuse: Protective device against anomaly currents which could damage the motor glow plugs during glow plug pre-heating. The capacity of this fuse is of 40A.
- **F2** Secondary fuse: Protective device against anomaly current which may damage components such as the solenoid valves, relays, hourmeters, etc. This fuse has a capacity of 16A..

- 5.9) OLEOPNEUMATIC PLANT (Fig. 3) --

-- 5-9-1) COMPRESSOR LUBRICATION SYSTEM --

The system includes the oil separator tank (Z), the thermostatic valve (U) on which, at the entrance, the oil filter (V) and the oil cooling radiator (M) are mounted.

As shown in fig. 4 the lower part of the oil separator tank (Z) acts as an oil tank, while the filtering part is situated at the top which separates the air from the oil.

On starting up the machine, the pressure generated by the compressor, makes the oil inside the tank flow through the conduit in the direction indicated by the arrow. A thermostatic valve (U) is positioned along the route, which according to the actual oil temperature, conveys it all or partially to the cooling radiator (M), more specifically:

- at temperatures of below 65°C, the thermostatic valve remains open and the oil in circulation is directly injected into the compressor, without going through the radiator (M).

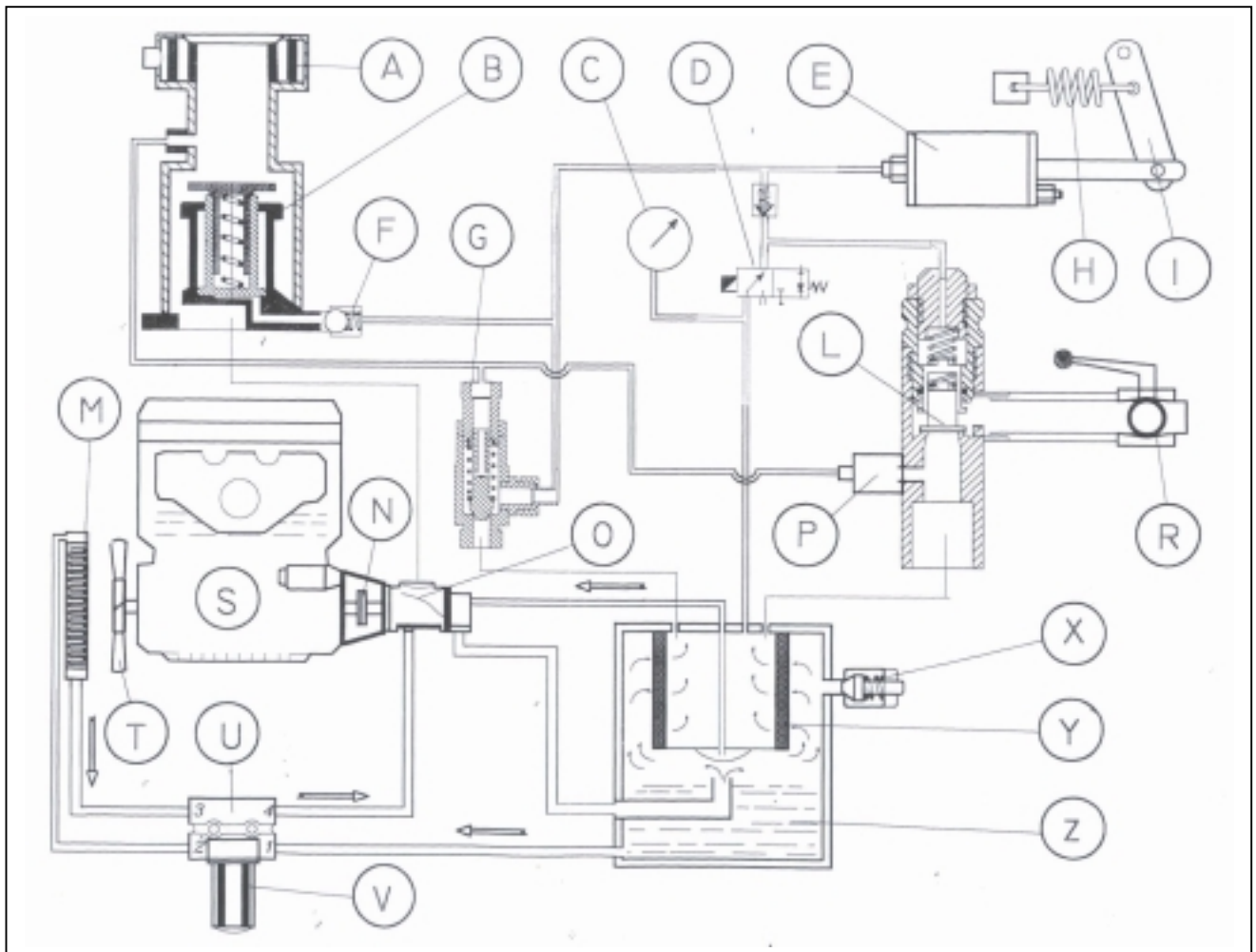

FIG. 3

During the working cycle the oil is heated and when it reaches a temperature of 65°C, the thermostatic valve (U) begins to close, thereby making it necessary for part of the oil to go through the cooling radiator (M).

When the oil temperature reaches 75°C, the thermostatic valve (U) closed completely and from then on all the oil in circulation goes through the radiator and is thereby cooled (M).

From the radiator (M) the oil is injected into the compressor (O).

The filter (V) has an internal "by-pass" valve which permits oil circulation even if it gets blocked. In which case the oil will circulate regularly without being filtered. It is therefore necessary to replace the filter at regular intervals, as indicated in the maintenance programme.

The cooled and filtered oil thereby reaches the compressor (O) and by means of the various internal channels it is distributed to the various parts (rotors, bearings etc) which are thereby cooled and lubricated. From the compressor (O), the oil mixed with compressed air is sent to the tank (Z), inside which the separator (Y) undertakes to separate it from the air.

We have mentioned that the separator filter (Y) provides to separate the air from the oil; however a very small quantity is still able to penetrate the inside of the filter, and deposits itself on the low and concave part of the same. It is sucked through the piping on which the calibrated nozzle and the single-direction valve are positioned. The latter impedes the return of oil into the oil separator filter when the machine is stopped.

-- 5-9-2) PNEUMATIC SYSTEM (Fig. 3) --

The system includes: the suction filter (A), the suction regulator (B), compressor (O), tank (Z) and the oil separator element (Y), the minimum pressure and non-return valve (L), the cock (R) and the maximum pressure valve (G), and the discharge solenoid valve (P).

The suctioned air, after having passed through the double stage filter (A) reaches the suction regulator, followed by the compressor which conveys it, together with the injected oil, into the oil separator tank. Where the air is separated from the oil. This separation process firstly comes about by means of centrifugal spinning and in the second stage with the use of the oil separator filter (Y).

The air which is cleansed of the oil, is conveyed by the minimum pressure valve (L), and only opens when the pressure in the tank reaches the pre-set value. This minimum pressure formed in the tank guarantees oil circulation even when the air discharge taps (R) are in fully open position.

It is however a good idea not to use tools and equipment, which excessively consume compressed air, and which may cause the tank pressure to fall to below 5-5.1 bar.

In fact prolonged working conditions at below 5 bar, may cause compressor overheating, due to insufficient lubrication, and inadequate air and oil separation, resulting in excessive lubricant consumption.

The solenoid valve (P), on stopping the machine, opens automatically, gently discharging all the compressed air still inside the system into the atmosphere.

The minimum pressure valve (L) also acts as a single-direction valve, impeding return into the compressed air unit of air coming from channels or tools connected to the machine.

-- 6) MACHINE HANDLING AND PARKING --

-- 6.1) LIFTING INSTRUCTIONS (Fig. 4) --

The bodywork has a special opening protected by a rubber covering, making it possible to easily reach the lifting hook, without lifting the bonnet. A lifting clevis is supplied for this purpose together with the compressor.



- a) Check that the lifting parts (crane, hoist etc) have the capacity to move the weight of the unit (see par. 2). If the crane is positioned on the vehicle, position the lateral anti-tilting stabilizers.
- b) Hitch the clevis and the rope (fig. 4) to the hook of the lifting means.
- c) Gently and smoothly lift the unit.
- d) Avoid making the machine sway during lateral movement.



The machine user must periodically check the state of efficiency of the lifting equipment described above, and must immediately replace it when it is no longer safe. No other hitching and lifting systems are permitted except those fitted on the machine.

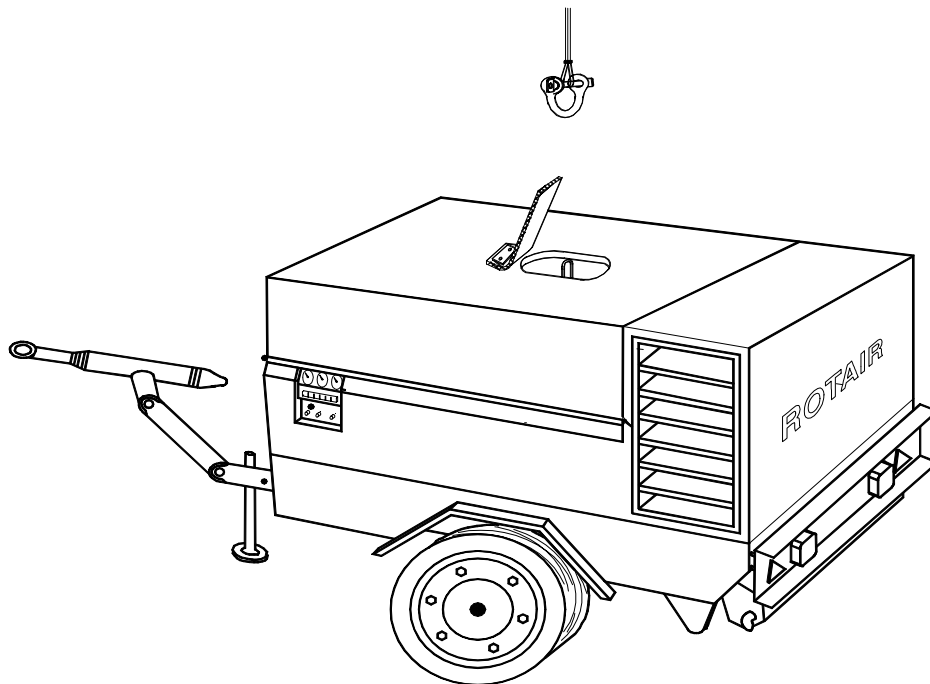

FIG.4

-- 6.2) TOWING INSTRUCTIONS (Fig. 5) --

This paragraph concerns machines suited to road circulation and thereby complete with regular homologation certificate.

For correct towing of the motor-drive compressor please follow these instructions:

a) Ensure that the towing eyelet or the ball attachment is compatible with the towing device fitted on the towing vehicle. Ensure that the vehicle has the capacity to tow a weight that is equal to or exceeding that of the motor-driven compressor to be towed.

b) Check the tyre pressure;

c) adjust the height of the eyelet so that it matches that of the towing vehicle hook; this is possible by means of the articulated joints of the tow-bar, to ensure that the drawbar which supports the eyebolt is as horizontally positioned as possible (Fig. 5a).

d) Securely tighten the joints using the relative levers, making sure that there is no play between the teeth of the joints. Insert the safety plugs.

e) Hitch the trailer to the vehicle, also connecting the safety cable.

f) Slacken the parking brake.

g) Position the foot, or the support wheel, in the highest possible position, making sure that the wheel cannot rotate on itself, in which case, remove it.

h) Connect the lighting system by inserting the plug of the motor-driven compressor into the relative plug positioned on the vehicle and check that all the indicator lights (position, direction, stop, number-plate) are working.

Should the machine be fitted with a coasting brake, it disengages automatically when it goes into reverse.

Regularly check the brakes and adjust as necessary.

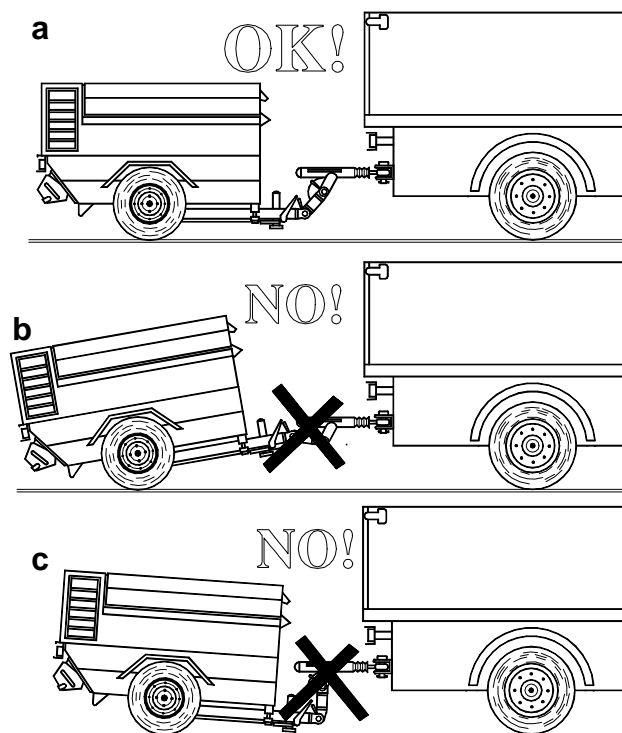

FIG. 5

For the maintenance of this towing drawbar, the axle and brake adjustment consult the enclosed manufacturer's manual.

-- 6.3) TRANSPORT INSTRUCTIONS (Fig. 6) --

The unit is despatched by Rotair fixed to a support suitable for movement by means of lift trucks; this wooden platform, facilitates the fastening to the flatbed of the transport vehicle and prevents this load from sliding.

For secure transportation proceed as follows:

1. Position the unit with the drawbar opposite to the cabin of the transport vehicle.
2. Position the drawbar as indicated in fig. 6.
3. Wrap the ropes around the drawbar and tighten using the winches supplied with the vehicle.
4. Position two wedges (part A) per wheel, fixing them to the vehicle flatbed, so that it does not move (fig. 6). Use wedges of adequate dimensions both in terms of height and width.
5. Travel at moderate speed.

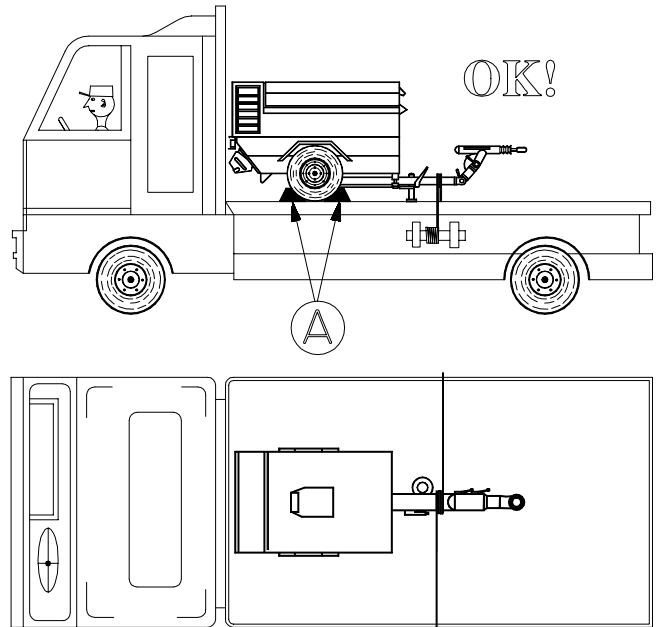

FIG. 6

-- 6-4) PARKING INSTRUCTIONS (Fig. 7) --

Before disconnecting the unit from the truck or from the lifting hook, adjust the height of the support foot (fig. 7 part B) or of the pivoting wheel so that the motor-driven compressor is in horizontally positioned.

In the case of sloping ground, position the wedges (part A) supplied with the machine either in front or behind the wheels thereby preventing the risk of any movement during the working stage.

Engage parking brake on those machines which have one (part C).

Operation of the machine hitched to the towing vehicle is prohibited.

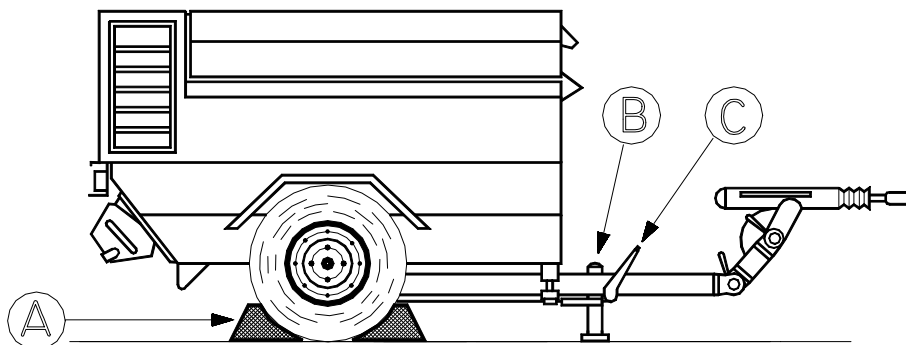

FIG. 7

-- 7) INSTRUCTIONS FOR MACHINE USE --

Specialized personnel are not required for the operation of this compressor, however it is essential that the operation personnel have read the manual and that they can put into practice all the instructions and advice provided.

It is only necessary to use specialized personnel for special maintenance operations, and those with the necessary technical know-how as provided by the "Rotair" assistance service.

-- 7.1) BEFORE STARTING UP THE MACHINE --

Before starting up the machine carefully proceed according to the following instructions:

-7.1.1) Make sure that the machine is level; using the support foot or wheel; an inclination of over 15° is not permitted;



-7.1.2) Check that the electric wires are connected to the battery terminals; when making connections always take the greatest care to ensure that the cable which comes from the starter motor is connected with the positive pole (+) of the battery and that the wire connected to earth is connected to the negative pole (-) of the battery;

-7.1.3) Check the motor oil level; refer to the instructions contained in the use and maintenance manual as concerns the type and quantity of lubricant to be used enclosed with this machine documentation;

-7.1.4) Check the compressor oil level: this operation must be undertaken no sooner than 5 (**five**) minutes after the machine has been stopped, this is in order to permit the lubricant in circulation to completely flow into the oil separator tank.

- Before unscrewing the cap of the filler (Fig. 8 part A) to which the graduated level rod is fixed make sure that the system is no longer under pressure (**the manometer should indicate 0 bar**)

- Remove the cap and clean the level indicator rod

- Tightly screw back the filler cap and then re-extract it to ensure that the lubricant level is between the two notches (minimum level and maximum level) on the rod.

- if necessary add the required amount of oil: the level must **never** exceed the maximum level notch.

- Use only the oil types indicated in paragraph 2 (Technical data).

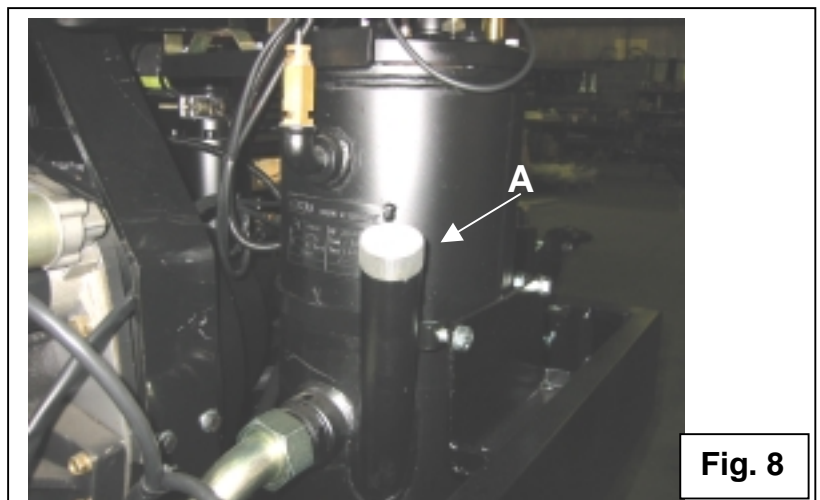

Fig. 8

-7.1.5 Check the level of the cooler liquid in the radiator (Fig.9).



ATTENTION: *The radiator cap (part T) must never be removed while the engine is hot, as this would cause a sudden escape of liquid that could cause serious burns.*

Any top-ups must be made using a mixture of water and anti-freeze liquid, in the percentages as indicated on the container of the same.

-7.1.6) Fuel check In the tank.

Use fuel with equivalent characteristics to those indicated in the motor manufacturer's manual

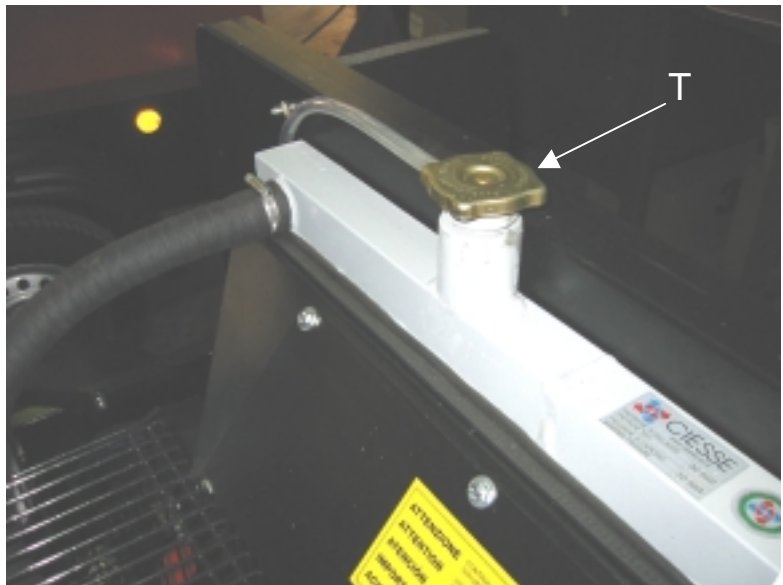

FIG. 9

-7.1.7) Carefully check to make sure that there are no traces of oil or fuel inside the machine as the result of top ups.

-- 7.2) STARTING UP --

Proceed as indicated in the illustrations of chap. 5.7

- 1) Fully close the air delivery taps
- 2) Position switch (4) to ON position, which will switch on the spark-plug pre-heating alternator and oil pressure indicators.
- 3) Wait for the spark-plug pre-heating indicator to go off.
- 4) Press the start button (3), until the engine starts. Should the engine fail to start immediately, do not insist in order to prevent the risk of damage to the starter motor, repeat the operations starting from points 3,4,5.



IMPORTANT: - Release the button as soon as the diesel engine begins to start.
- Avoid extended starting operations, of over 10 seconds duration.
- In the event of difficult start conditions, repeat the operation with a series of short, starting operations at intervals.

5) Once the engine is engaged, it will run at minimum speed for about 40 seconds; the pressure gauge will indicate a pressure level of between 2-3 bar, while the indicator lights on the control panel must all be off..

Should one or more of the indicators still be on after 5-6 seconds, immediately stop the machine to find the cause.

After 40 seconds the motorized compressor will automatically enter working mode: accelerate the engine, open the suction valve and the gauge pressure will reach maximum calibration values

6) Then connect the compressed air delivery pipes to the relative tools.

7) Gradually open the taps.

-- 7.3) DURING THE WORKING STAGE --

- 1) The machine must always operate with bonnet lowered and closed.
- 2) The suction inlets must be constantly checked to prevent any obstruction by foreign particles such as paper, plastic, etc.
- 3) Check the fuel level.

-- 7.4) STOPPING --

1) Fully close the delivery taps (R).

2) Position switch (4) to OFF; the motorized compressor will act to de-pressurize the machine until the gauge pressure reaches a value of 3.5 bar before stopping. The control leds will flash during the de-pressurization stage

-- 8) MACHINE SETTING AND TUNING --

-- 8.1) CHECK ON MOTOR RPM MAXIMUM SPEED --

The calibration of the maximum rpm is set and sealed by the constructor. It cannot be altered for any reason.

Any tampering with the sealing and consequent variation in the max. rpm, will result in the immediate cancellation of the guarantee terms, both in relation to the motor and compressor parts.

Any checks and setting of maximum and minimum rpm must be undertaken by specialized personnel, complete with refractive speedometer devices and complete with protective ear-muffs.

Proceed as follows:

- 1) Start up the machine as described in paragraph 7.2 .
- 2) Keep the cocks closed and check that the pressure indicated on the gauge on the control panel corresponds to that indicated in paragraph 1. Should they fail to correspond, proceed with pressure setting following the instructions provided in paragraph 8.2 .
- 3) Slowly open the cock until the working pressure reading appears. See paragraph 1.
- 4) Ensure that the motor has been completely accelerated, proceeding as follows, with the aid of fig.11:

4.1) ensure that the rod (P) is free to undertake slight oscillation around the pin (A). This rod mobility demonstrates that the piston (C) has totally returned and that there is nothing to impede motor acceleration. While in the event that the piston (C) appears to impede the lever (P) and it is not found to be totally free, try and increase the spring traction force (M) according to the following procedure:

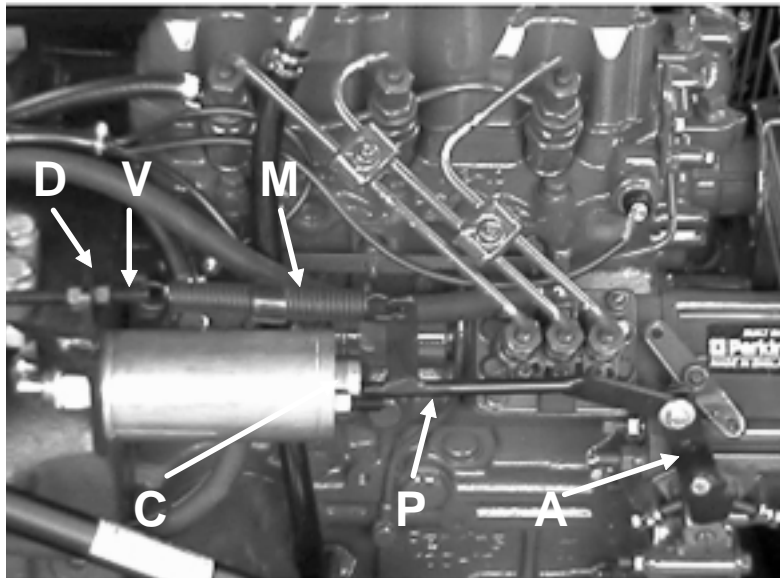

FIG.11

4.2) Stop the machine, release spring (M) of rod (A), loosen nut (D) and tighten the tie rod (V) making it go round 4-5 times. Then re-hitch the spring to the rod and repeat the operations of points 1-2-3-4.

If, after increasing the spring (M) pulling potential as described above, the piston (C) continues to impede the rod (P) it is necessary to check the correct function of the acceleration device by checking the **maximum pressure regulation valve** (fig. 16, page 26) proceeding as follows:

Dismantle and clean the various components, carefully checking to make sure that there are no foreign bodies that may impede the perfect sealing of the housing of the valve itself.

Should any abrasions or scratches be noted on the components it is necessary to replace the damaged parts or complete valve.

Once replacement has been made the valve must be calibrated according to the instructions in paragraph 8.2 .

5) After ensuring that the motor is completely accelerated, record the rpm value using the speedometer. Compare the reading with the indication in paragraph 2: A variation of $\pm 3-4\%$ is permitted.

6) In the event that with the acceleration rod pressed down and with motor therefore fully accelerated, the number of revs is found to be significantly lower than that indicated on the plate (at least 150 revs less), the cause of the defect causing lack of motor power must be found, probably being due to the injection feed devices being insufficiently efficient (fuel filter, injectors, feed pump, injection pump, etc.) .

It is advisable that all the interventions on the injection device (injectors, feed pumps, etc.) be undertaken by the "**Assistance service**" authorized by the manufacturing company, particularly if the machine is still under guarantee.

-- 8.1.2) CHECK ON THE MINIMUM MOTOR RPM --

- 1)** Start the machine according to the instructions in paragraph 7.2 .
- 2)** Keep the air delivery cocks fully closed.
- 3)** Check that the pressure indicated on the gauge on the control panel corresponds to the value indicated in paragraph 2, if it does not, regulate according to the indications in paragraph 8.2 .
- 4)** Using the refractive speedometer device, read the motor rpm which should correspond to that indicated in paragraph 2; variations of over 5% of the value are not permitted.

Should the minimum rpm need to be regulated proceed as follows (fig. 12):

4.1) Using a 13 mm wrench loosen the lock-nut (D) and use a screwdriver to tighten the regulation screw (V) (to increase revs) or to loosen it (to reduce the revs), re-securing it using the lock-nut (D).

4.2) Start the machine by repeating all operations as indicated in points 1 - 2 - 3 - 4 of this paragraph until the desired value is obtained as indicated in paragraph 2.

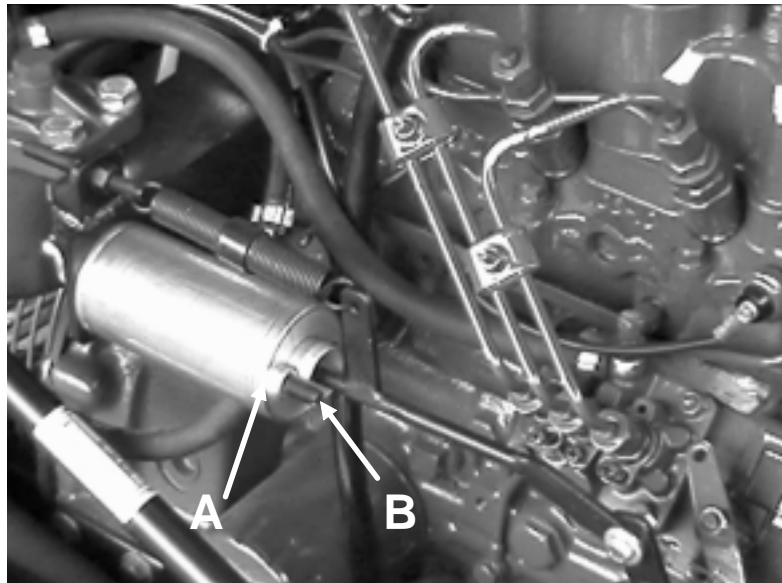

FIG.12

-- 8.2) CHECKING AND SETTING OF THE MAXIMUM FINAL VALUE (Fig. 13) --

The maximum final pressure is set during the machine testing stage. With motor running at minimum and cocks closed, the pressure value indicated on the gauge on the control panel must correspond to that indicated in paragraph 2. In the event of a variation of over $\pm 5\%$ proceed with **calibration of the maximum pressure valve** as follows:

- 1) Keep the machine running with cocks closed.
- 2) Loosen the lock-nut (2) fig. (13)
- 3) Tighten the regulation screw (1) to increase the pressure.
Loosen regulation screw (1) to reduce the pressure.
- 4) Re-secure the counter-nut (2).
- 5) Slightly open the air delivery cock for 3-4 seconds in order to accelerate the motor, then close again. Repeat this operation 2 - 3 times for valve positioning.

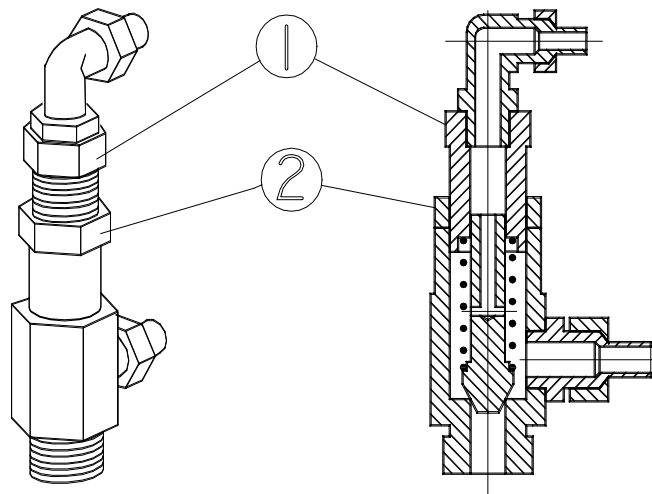

FIG. 13

- 6) Read the pressure on the gauge and if necessary repeat calibration as indicated in points 2 - 3 - 4, until a value as indicated in paragraph 1 is obtained 1.



WARNING: Should the gauge have a jerky discontinuous function, it must be replaced. Therefore before undertaking any calibration of the maximum and minimum pressure valves, make sure that the gauge itself is efficient and reliable.

-- 8.3) MINIMUM PRESSURE CHECKING AND SETTING (Fig. 14) --

The purpose of this valve is to ensure that during operation the pressure in the oil separator tank does not drop under the minimum value, in order to ensure the necessary oil circulation.

CHECKING AND SETTING:

- 1) Start up the machine as described in paragraph (7.2).
- 2) With motor warm, at right temperature, gradually proceed to fully open the air cock; the motor will reach maximum rpm and a pressure of between 4.5 - 5 bar must appear on the gauge.



Should a different pressure appear than that indicated above, proceed with setting as follows (fig. 14):

- 3 Release the lock-nut (1) .
- 4 Tighten the regulation screw (2) to increase the pressure to the desired value.
- 5 Loosen the regulation screw (2) to reduce the pressure to the desired value
- 6 Tighten the lock nut (1) and close the cocks.
- 7 Slowly re-open the air cock and then close it again repeating the operations several times in order to permit the valve to settle into place.

Fig. 14

-- 8.4) SAFETY VALVE CHECK (Fig. 15) --

This valve is positioned on the oil separator tank and operates to discharge any accidental overpressure.

This valve is calibrated and checked at the factory, and cannot therefore be altered or tampered with for any reason.

Its efficiency can be checked periodically as follows:

1. Start up the machine as described in paragraph (7.2).
2. With cocks closed and motor running at a minimum, lift the pin upwards using pliers, as indicated in fig. 18, and release as soon as the valve can be seen to discharge air.

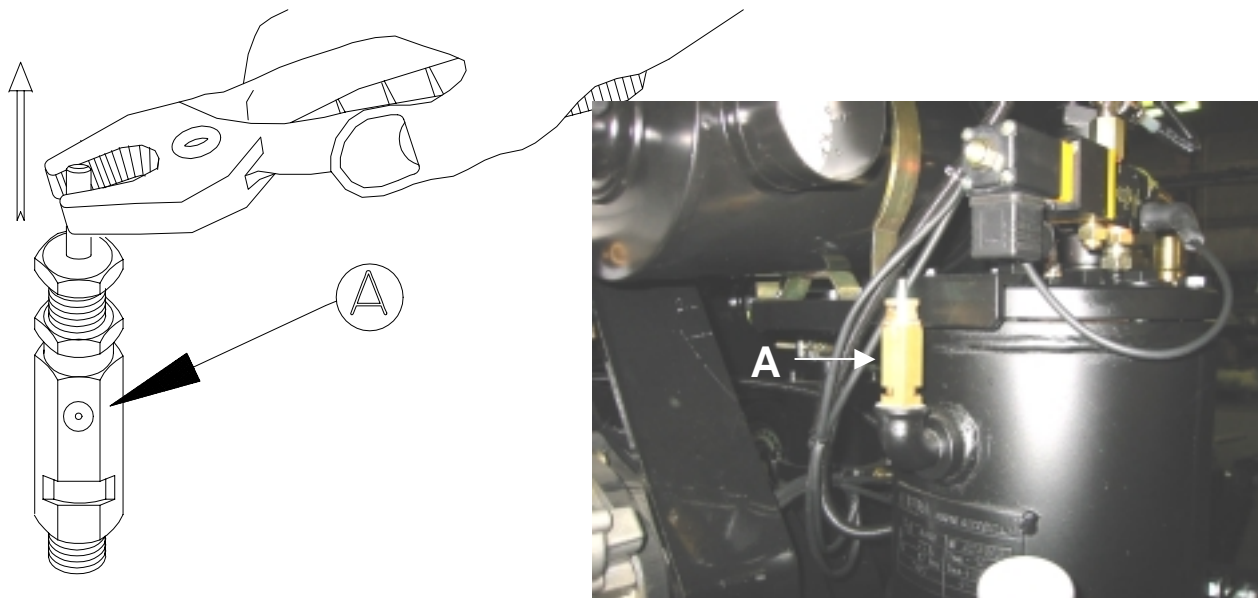

FIG. 15



WARNING: *The air which escapes from the valve during this checking operation is mixed with oil particles and therefore to avoid soiling the operator and the inside of the machine it is advisable to bind the valve with a cloth.*

If the pin fail to rise after being guided with the pliers, thereby preventing valve breathing, it must be replaced at once.

New replacement safety valves must be of the same type as the original and must be complete with conformity certificate issued by the manufacturer.

As this valve plays a vital role in preventing any dangerous overpressure which could cause the piping, or the oil separator tank to burst, it is important to request the original spare part from ROTAIR SPA citing the machine serial number.

ROTAIR will not accept any responsibility in the event of the use of non-original and non-conforming valves.

-- 9) MAINTENANCE PROGRAMME --

This programme indicates all the necessary periodic operations to be undertaken in the machine and which are essential to ensure its efficient function and long life.

ORDINARY MAINTENANCE

Can be undertaken by the personnel who operate on the machine and includes all those periodic programmed maintenance operations such as checks on the oil level, air filters, refuelling, cleaning operations and checks to isolate any eventual leakage of lubricant or fuel inside the machine.

Here follows a list of all the operations relating to the compressor part, in order of frequency, while for those relating to the "motor" please refer to the USER AND MAINTENANCE MANUAL, supplied by the motor construction company with the machine.

-- 9.1) DAILY CHECKS --

-- 9.1.1) DAILY AND BEFORE STARTING UP THE MACHINE --

- Check on the compressor oil level (paragraph 7.1.4).
- Motor oil level check (consult manufacturer's manual).
- Check for any lubricant or fuel leakage.
- Refuelling (7.1.6).
- Check on the cooling liquid level (in the case of liquid cooled machine) (7.1.5).

-- 9.1.2) DAILY AND WITH MOTOR RUNNING --

- Check on all the indicator lights positioned on the control panel (7.2, 7.3).
- Check on the maximum pressure level (8.2).
- Check on the minimum pressure level (8.3).

-- 9.2) WEEKLY --

- Check on air compressor filter (10.1).
- Check on motor air filter (see manufacturer's manual).
- Check on the electrolyte level in the battery (10.2).
- Check on the tyre pressure (10.3).



WARNING: *Should the compressor operate in a very dusty environment the air filter must be checked, cleaned or replaced more often than indicated above.*

-- 10) PERIODIC MAINTENANCE --

-- 10.1) AIR FILTER CHECKING (Fig. 16) --

- This check must be undertaken periodically after every 100 working hours, however should the machine operate in particularly dusty environments it may be necessary even daily.
- The filter consists of two filtering cartridges (1st and 2nd stage): to check them loosen the nut (fig. 16, part 1) and extract the cartridge of the 1st stage part 3.

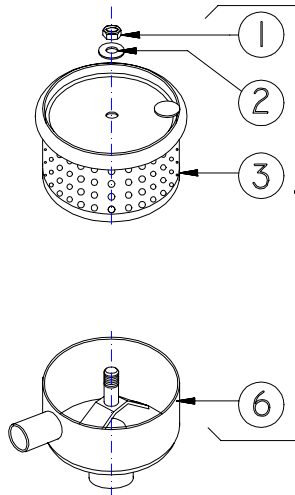

Fig. 16

- Should any traces of dust be noticed on the cartridge of the 2nd stage also part 5, extract this one also, unscrewing the nut part 4.

These filtering cartridges, parts. 3 and 5 may be cleaned a few times using jets of compressed air, but never washed.

They must however be replaced every 500 working hours.

-- 10.2) BATTERY CHECK --

- Unscrew the caps of the elements and check the electrolyte liquid level. Top up with distilled water if necessary.

-- 10.3) TYRE PRESSURE CHECK --

- Consult paragraph 2 as concerns the tyre pressure value 2.

-- 10.4) COOLING RADIATOR CLEANING --

The cooling liquids of the compressor and motor are cooled by a radiator which must therefore be kept clean to ensure that the ventilation air can easily pass through its honeycomb flaps.

Should the flaps become clogged with dust or other particles, there is a risk of harmful overheating of the mechanical parts of the screw compressor, seriously jeopardizing its function and duration. It is therefore advisable to check it regularly and clean it using compressed air or wash it using a pressurized water jet.

-- 10.5) OIL RECOVERY NOZZLE CHECKING AND CLEANING --

This must be undertaken in the event of any leakage of nebulized oil mixed with compressed air, as follows (fig. 20):

- Unscrew the connection (Z) positioned at the centre of the tank.
- Inside the connection (Z) is a nozzle (U); ensure that its gauged hole is not clogged (blow with a jet of compressed air).
- Re-assemble.

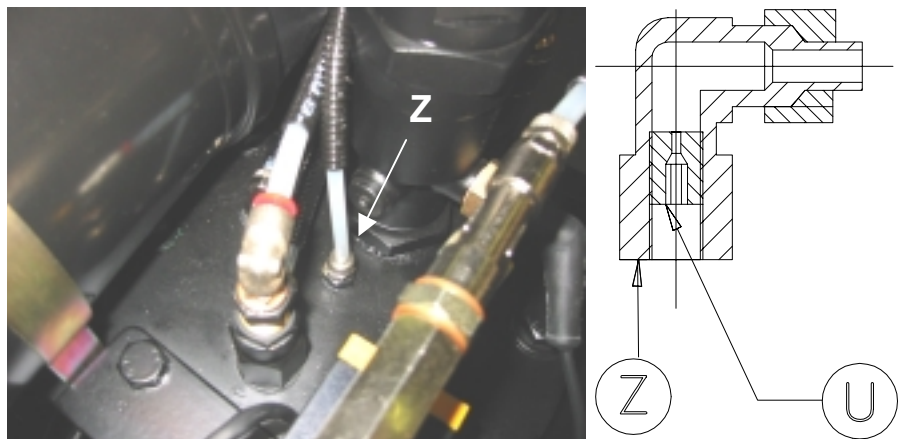

FIG. 17



WARNING: During the regular function of the compressor it is normal to note a certain amount of oil flow out of the transparent piping which starts from the connection (Z), towards the compressor head.

-- 10.7) BRAKING DEVICE CHECK --

As concerns this operation consult the use and maintenance manual relative to the axial - brake - overrun, compiled by the manufacturer and which forms part of the documentation supplied together with the machine.

-- 10.8) WHEEL BLOCKING SCREW CHECK --

Using a special spanner ensure that there are no loose screws. Check.

-- 10.9) COMPRESSOR OIL FILTER REPLACEMENT (Fig. 19 --

- Use a chain pipe wrench to unscrew the filter to be replaced (part A).
- Oil the seal of the new filter which must be tightened and secured **by hand only**.
- Start up the machine and ensure that there is no leakage near the seal; if there is; switch off the machine and check the condition of the machine and that it is correctly positioned in its slot.

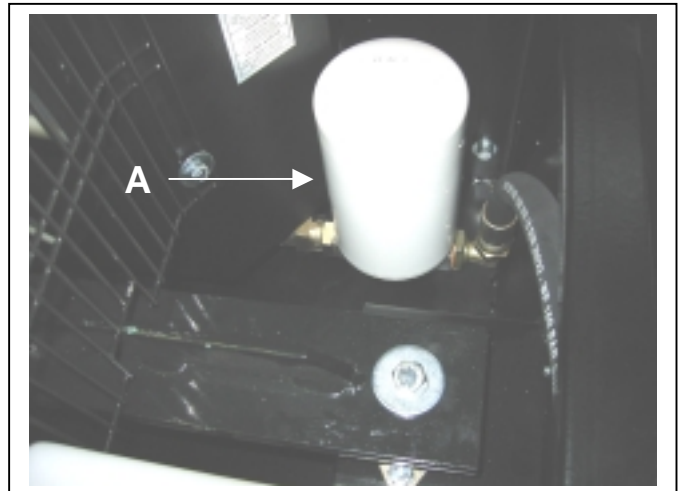

FIG. 19



WARNING: *The old filter is impregnated with polluted and harmful mineral oil. It must therefore be sent to the special collection centres.*

-- 10.10) COMPRESSOR OIL REPLACEMENT (Fig. 20) --

Compressor oil replacement must also be undertaken taking into account the working conditions under which the machine operates (dusty conditions, very high temperatures etc) and in any event at intervals which must never exceed 1500 working hours, or at least once a year.

The relative filter must also be changed when oil is changed (paragraph 10.9).

Carry out this operation with the machine still warm, as follows: (fig. 20)

- 1) Make sure that there is no pressure in the tank;
- 2) Unscrew the filler cap of the tank itself (part B);
- 3) Unscrew the emptying cap (part A) after having placed a container of adequate capacity beneath it;
- 4) Unscrew and replace the oil filter cartridge

(fig. 19 part A);

- 5) When the oil has completely come out, screw back the cap (part A) making sure to replace the copper seal. Pour the lubricant oil through the fuller mouth to the right level, as indicated in paragraph 7.1.4 (quantities and characteristics as indicated in paragraph 2)
- 6) Close the filler (fig. 8 part A) the machine checking to make sure there is no oil leakage. Allow the machine to heat up and then stop it. Check the oil level again after 15 minutes and top up as necessary.

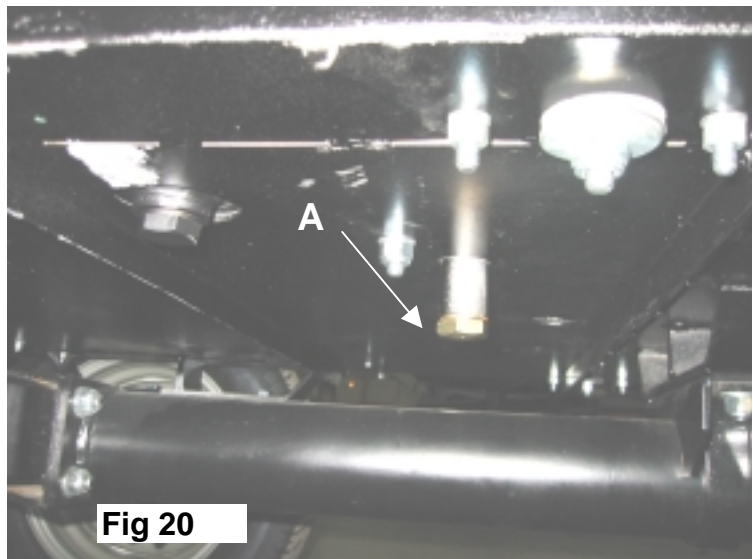

WARNING: The replacement oil must be collected in a can and consigned to the specialized centres authorized in the collection of pollutant products. It must not be disposed of in the ground or lakes or rivers.

10.11) OIL SEPARATOR ELEMENT (Fig. 21) --

-- 10.11.1) CHECKING OF OIL SEPARATOR ELEMENT --

This operation is reserved for specialized and qualified personnel.

The frequency is usually estimated as being of about every 2000 working hours, but it strictly depends on the observance of all the maintenance regulations indicated in this manual.

Insufficient oil in the tank, failure to comply with the lubricant replacement frequency indications or use of the machine with clogged cooling radiator, may all result in **serious damage** to the separator filter.

Therefore after having checked the condition of the recovery nozzle (operation described in paragraph 10.5) and having made sure of the correct oil level in tank, should there be any further traces of oil in the compressed air, it is necessary to replace the oil separator filter (fig. 21).

To find out the degree of blockage of the oil separator filter proceed as follows:

- install a gauge at the top of the oil separator and check that the one on the machine is efficient.
- Start up the machine and position the switch to "WORK" (see paragraph 7.2)
- Partially open the delivery piping until the control panel gauge indicates the working pressure.
- Read the pressure on the gauge positioned at the top of the oil separator and compare the two values: should a difference of over 1 bar be found, it is a clear indication that the filter is blocked and it must be neither cleaned or washed, but replaced.

-- 10.11.2) INSTRUCTIONS FOR THE REPLACEMENT OF THE OIL SEPARATOR ELEMENT --

1. The operation must be undertaken with machine off and no pressure in the oil separator tank.
2. Disconnect all the pipes from the connections positioned on the closure flange of the separator tank, marking them so there is no problem on re-assembly.
3. Loosen the screws (fig. 21, part A) and remove the flange (B).
4. Extract the filtering element (D) together with the seals (C) and (E).
5. Assemble the new seal (E) in the relative slot which has been previously cleaned. Endure that a metallic insert has been clipped to the seal in order to avoid the isolation of the filter and the accumulation of static electricity. Otherwise there is a risk of the separator filter catching fire.
6. Insert the new separator element correctly positioning it into the relative slot.
7. Assemble the second seal (C) with the same precautions as above.

8. Reassemble the flange (B) in the pre-assembly position.

9. Tighten the bolts,(A), with a tightening torque of 80 Nm.
10. Re-connect all the pipes to the respective fittings.
11. Start up the machine ensuring there is no leakage between the cap and the tank.
12. Allow the machine to operate for 10-15 minutes with closed cocks and switch positioned on "WORK".
13. Stop the machine with tank depressurized to 0 bar, re-check the screw tightening (A).

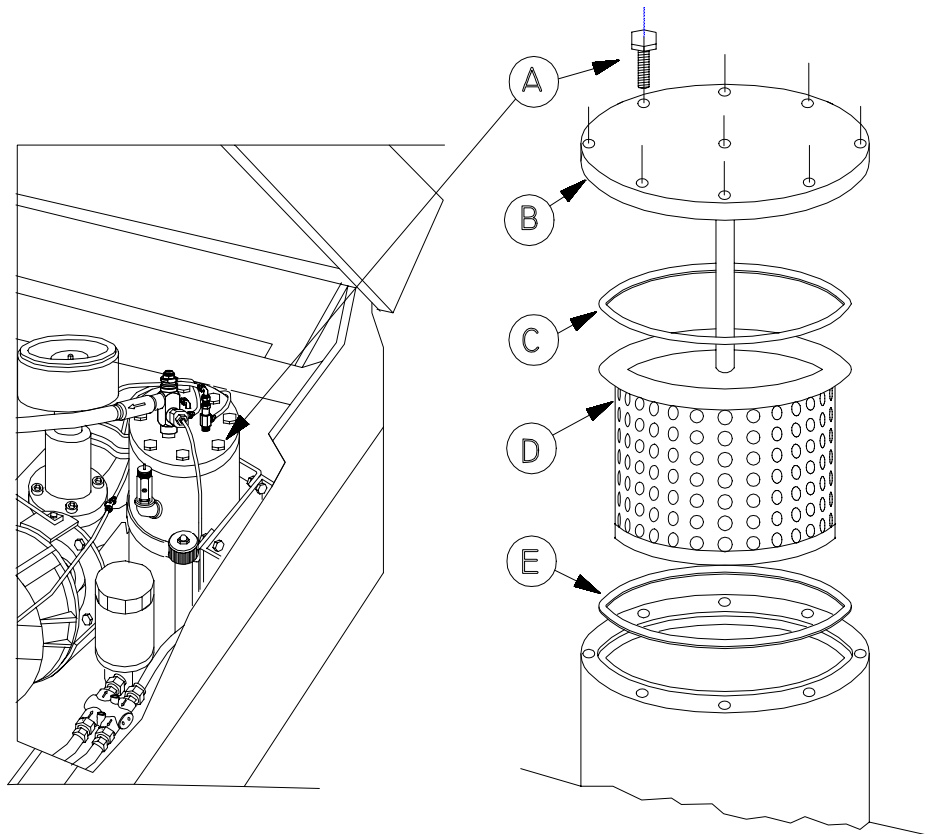

FIG. 21

<u>ANOMALY</u>	<u>CAUSES</u>	<u>SOLUTIONS</u>
Motor fails to start	Flat or defective battery.	Recharge or replace if necessary.
	Battery wire cables either oxidized or loose.	Clean and tighten them.
	Lack of fuel.	Fill the tank.
	Defective fuel solenoid valve.	Request intervention of the customer assistance service of the motor constructor;
	Air in the fuel pipe.	Find out where the infiltration come from by carefully checking all piping.
	Defective injection pump	Request intervention of the customer assistance service of the motor constructor.
	Defective temperature probes.	They are situated on: <ul style="list-style-type: none"> - motor cylinder head; - compressed air outlet; - oil separator tank. Detach the electric wire of each until the defective one is found, then replace it. The temperature indicator of a control panel with efficient probes must go out
	Defective starter motor. Injector faults.	Request the intervention of the motor manufacturer's customer assistance service.

ANOMALY

CAUSES

SOLUTIONS

On opening the cocks the motor fails to accelerate.

Defective maximum pressure regulation valve.

Dismantle and carefully check the spring and the conical housing. If the defect cannot be repaired the valve must be replaced. Re-position it and set the maximum pressure according to the instructions of paragraph

The motor accelerates but no air escapes from the cocks

Blocked minimum pressure regulation valve.

Dismantle and check that the piston is free to move. Check that the spring is in good conditions. If the defect cannot be repaired replace it. Re-position it and set the minimum pressure according to the instructions in paragraph 8.3.

<u>ANOMALY</u>	<u>CAUSES</u>	<u>SOLUTIONS</u>
<p>The machine comes to a sudden stop and can only be re-started after several minutes wait.</p>	<p>One of thermal probes reveals a temperature anomaly and therefore stops the machine.</p>	<p>By disconnecting them one at a time, find the probe which causes the stoppage. If it is found to be the one positioned on the motor, check the motor oil level, the tension and conditions of the alternator belt.</p> <p>For water cooled water check the cooler liquid level. If it is found to be the probe positioned on the compressor check the oil level in the tank and top up as necessary; check the cooler fan and clean the radiator; replace the compressor oil filter.</p> <p>If it is found to be the probe positioned on the oil separator tank, check the oil separator filter according to the instructions of par.10.11, and replace as required.</p>
<p>*****</p> <p>The motor fails to reach the envisaged maximum envisaged compressor rpm and fails to perform.</p>	<p>*****</p> <p>The accelerator piston spring is broken or must be stretched.</p> <p>Insufficient motor revs.</p>	<p>*****</p> <p>Check the tension of the accelerator piston spring (par. 8.1).</p> <p>Have the motor injection system checked by qualified personnel. Replace the fuel filter. Drain the fuel tank (par. 10.6).</p>

<u>ANOMALY</u>	<u>CAUSES</u>	<u>SOLUTIONS</u>
Oil leakage from cocks.	Minimum work pressure too low.	Adjust it according to instructions of par. 8.3.
	Excessive oil in the tank.	Restore correct level (par. 7.1.4).
	The machine works in a non-horizontal position	Position the machine so it is level.
	Blocked oil recovery nozzle.	See par. 10.5.
	Defective oil separator filter	See par. 10.11.
*****	*****	*****

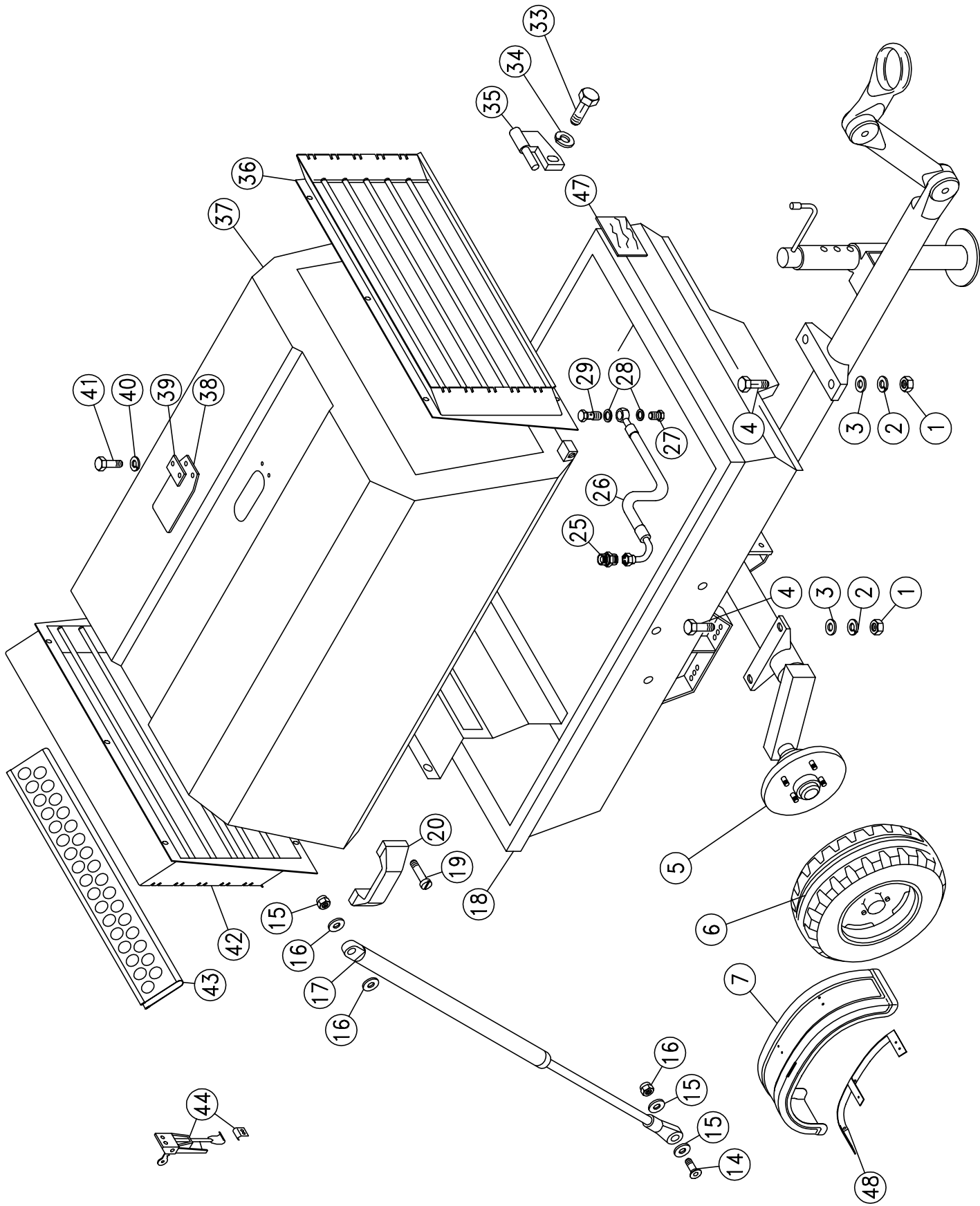

DETAILS LIST OF MDVN 36 AP

TAB. 1

POSITION	DESCRIPTION	CODE	QUANTITY
1	M12 HEXAGONAL NUT	135-060-S	6
2	GROWER DIAM.12	139-060-S	6
3	FLAT WASHER 13X27X2,5	015-047-S	6
4	T.E. SCREW 12X35	132-193-S	6
6	TYRE	054-100-S	2
7	PLASTIC MUDGUARD	055-010-S	2
14	T.E. SCREW 8X40	132-105-S	2
15	FLAT WASHER 8X17X1,5	015-030-S	4
16	SELF-LOCKING NUT M8	137-040-S	2
17	HOIST	091-095-S	2
18	CHASSIS	038-113-S	1
19	TCEI SCREW 8X25	133-133-S	6
20	HANDLE	209-009-S	3
25	DOUBLE SCREW 1/2"-3/4"	187-052-S	1
26	PIPING 1/2" F90+OC L=670	065-174.2-S	1
27	1/2" HEXAGONAL HEAD IRON CAP	106-125-S	1
28	COPPER WASHER DIAM. 21	015-012-S	1
29	1/2" HOLLOW SCREW	188-100-S	1
33	T.E. SCREW 12X30	132-192-S	2
34	FLAT WASHER 13X27X2,5	015-047-S	2
35	FIXED LEFT HINGE	007-023-S	1
36	FRONT AIR INTAKE	022-051-S	1
37	INTERNAL BODYWORK	036-177-S	1
38	HOIST HOOK RUBBER INSERT	177-200-S	1
39	BODYWORK SLOT RUBBER STOP INSERT	208-004-S	1
40	FLAT WASHER 6X12X1,5	015-027-S	2
41	T.E. SCREW 6X25	132-065-S	2
42	REAR AIR INTAKE	022-051-S	1
43	AIR INTAKE SOUND DAMPENED MATERIAL	097-054-S	10
44	LOCK	128-010-S	1
47	IDENTIFICATION PLATE	238-1453-S	1
48	MUDGUARD SUPPORT	010-310-S	2

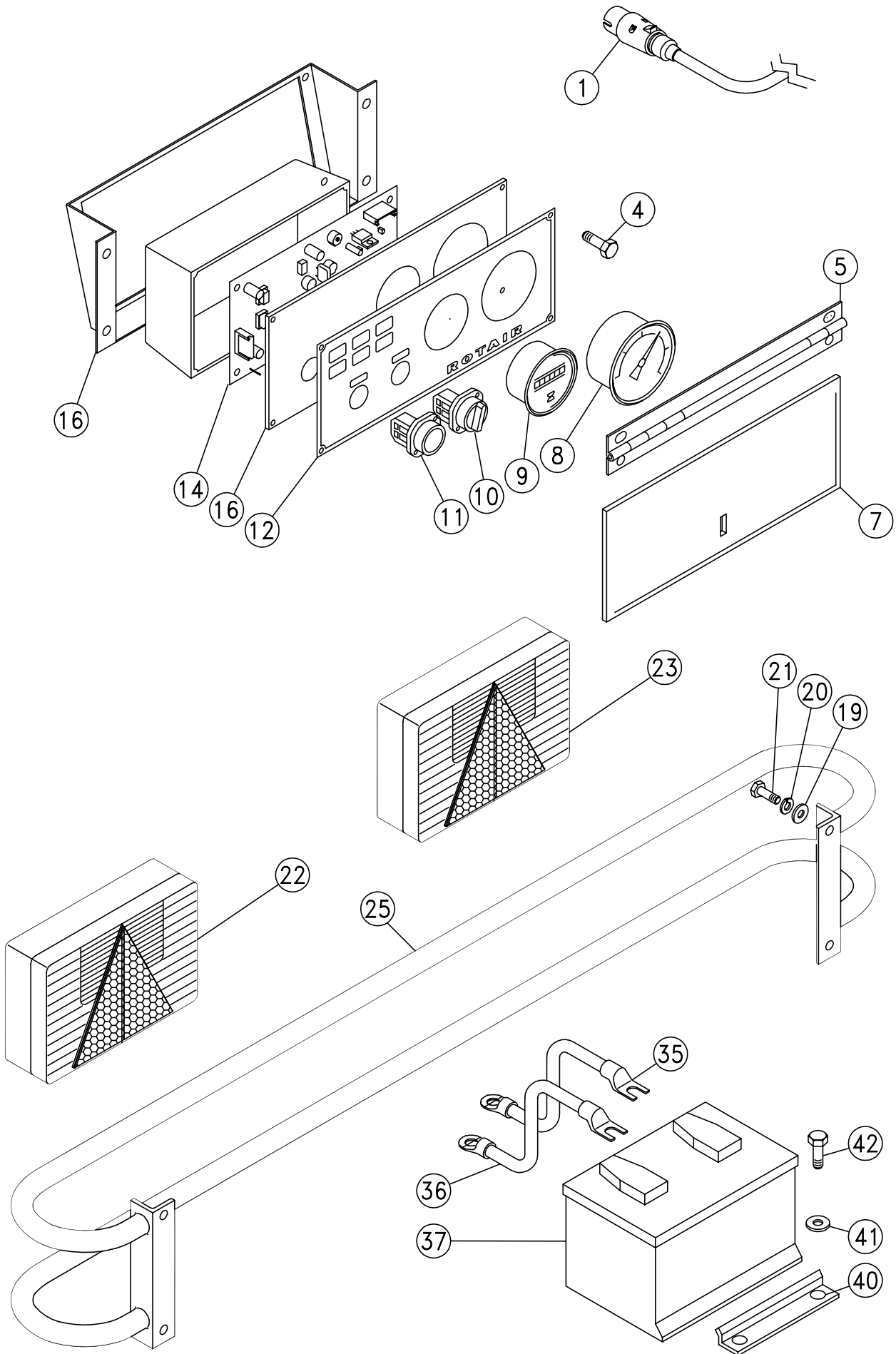

DETAILS LIST OF MDVN 36 AP**TAB. 2**

POSITION	DESCRIPTION	CODE	QUANTITY
1	LIGHT WIRING	224-528-S	1
4	POERLIE ROUND HEAD SCREW 6X16	243-009-S	4
5	CONTROL PANEL HINGE	007-029-S	1
7	PLEXIGLASS FLAP	057-020-S	1
8	MANOMETER	206-010-S	1
9	ELECTRONIC COUNTER	180-010-S	1
10	TWO-POSITION SWITCH	249-020-S	1
11	GREEN BUTTON	154-055-S	1
12	CONTROL PANEL STICKER	238-163-S	1
14	ELECTRONIC CARD	269-415-S	1
16	CONTROL PANEL CONTROL PANEL	040-0425-S	1
19	FLAT WASHER 10X21X2	015-032-S	4
20	GROWER DIAM.10	139-050-S	4
21	T.E. SCREW 10X30	132-143-S	4
25	BUMPERS	032-117-S	1
35	NEGATIVE BATTERY CABLE	252-061-S	1
36	POSITIVE BATTERY CABLE	252-075-S	1
37	BATTERY	174-007-S	1
40	BATTERY STOP	115-009-S	1
41	FLAT WASHER 6,6X18X2	015-029-S	2
42	T.E. SCREW 6X20	132-063-S	2

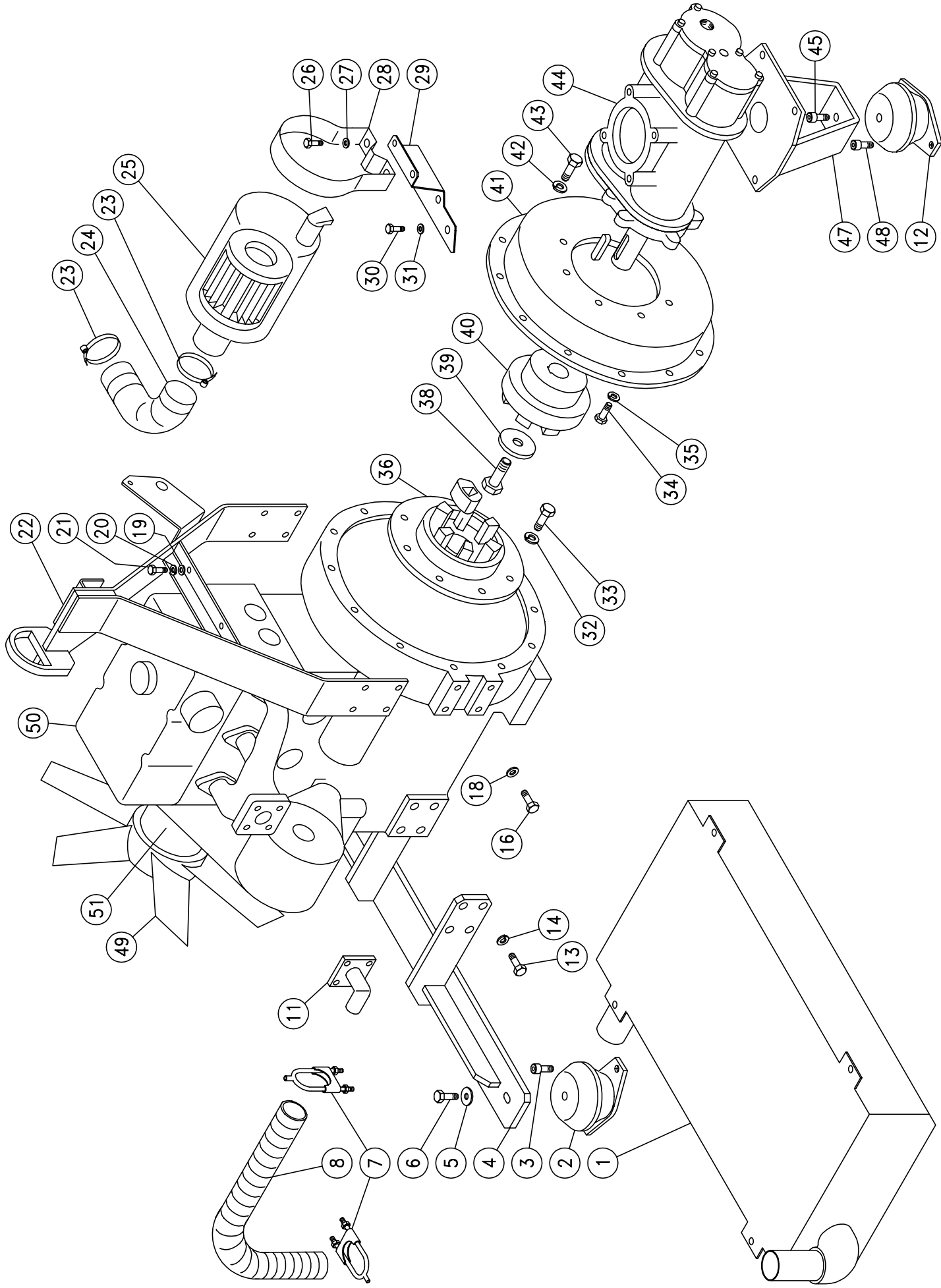

DETAILS LIST OF MDVN 36 AP

TAB. 3

POSITION	DESCRIPTION	CODE	QUANTITY
1	SILENCER	042-083-S	1
2	SILENT BLOK	061-023-S	2
3	T.E. SCREW 8X25	132-102-S	4
4	MOTOR SUPPORT	039-123-S	1
5	FLAT WASHER 10X40X2,5	015-037-S	2
6	T.E. SCREW 10X80	132-153-S	2
7	STRIP	149-170-S	2
8	INOX PIPE DIAM. 50	090-0105-S	1
8	GLASS FITTING DIAM. 60 FOR STAINLESS STEEL PIPE	097-031-G	1
11	EXHAUST GAS COLLECTOR	119-066-S	1
12	SILENT BLOK	061-006-S	1
13	T.E. SCREW 14X35X1,5	132-2435-S	8
14	GROWER DIAM. 8	139-040-S	8
16	T.E. SCREW 3/8-16 UNC L=1"	132-701-S	8
18	FLAT WASHER 10X21X2	015-032-S	8
19	FLAT WASHER 8X17X1,5	015-030-S	2
20	GROWER DIAM. 8	139-040-S	2
21	T.E. SCREW 8X20	132-101-S	2
22	HOISTING ATTACHMENT HOOK	017-049-S	1
23	PIPE-TIGHTENING STRIP 40/60	149-135-S	2
24	ENGINE AIR FILTER ELBOW	111-102-S	1
25	CONTAINER UNIT + AIR FILTER MOTOR	014-415-S	1
26	T.E. SCREW 6X20	132-063-S	2
27	FLAT WASHER 6X18X2	015-029-S	2
28	AIR FILTER STRIP	149-383-S	1
29	ENGINE AIR FILTER SUPPORT SECTION	120-396-S	1
30	T.E. SCREW 6X20	132-063-S	2
31	FLAT WASHER 6X18X2	015-029-S	2
32	FLAT WASHER 8X17X1,5	015-030-S	8
33	T.E. SCREW 5/16-18 UNC L=1"1/4	132-702-S	8
34	T.E. SCREW 8X40	132-105-S	8
35	GROWER DIAM. 8	139-040-S	8
36	ENGINE JOINT	006-1051-S	1
38	T.E. SCREW 12X35	132-193-S	1
39	JOINT STOP WASHER	015-068-S	1
40	COMPRESSOR JOINT	006-0871-S	1

ROTAIR S.p.A.

41	ENGINE BOX	020-102-S	1
42	FLAT WASHER 10X21X2	015-032-S	12
43	T.E. SCREW 3/8-16 UNC L=1"	132-701-S	12
44	SCREW ASSEMBLY R 186 DF	024-045-F	1
45	T.E. SCREW 10X75	132-152-S	2
47	COMPRESSOR SUPPORT	027-076-S	1
48	T.E. SCREW 8X25	132-102-S	4
49	FAN	083-190-S	1
50	PERKINS MOTOR 403 C/15	165-971-S	1
51	FAN SUPPORT	028-077-S	1

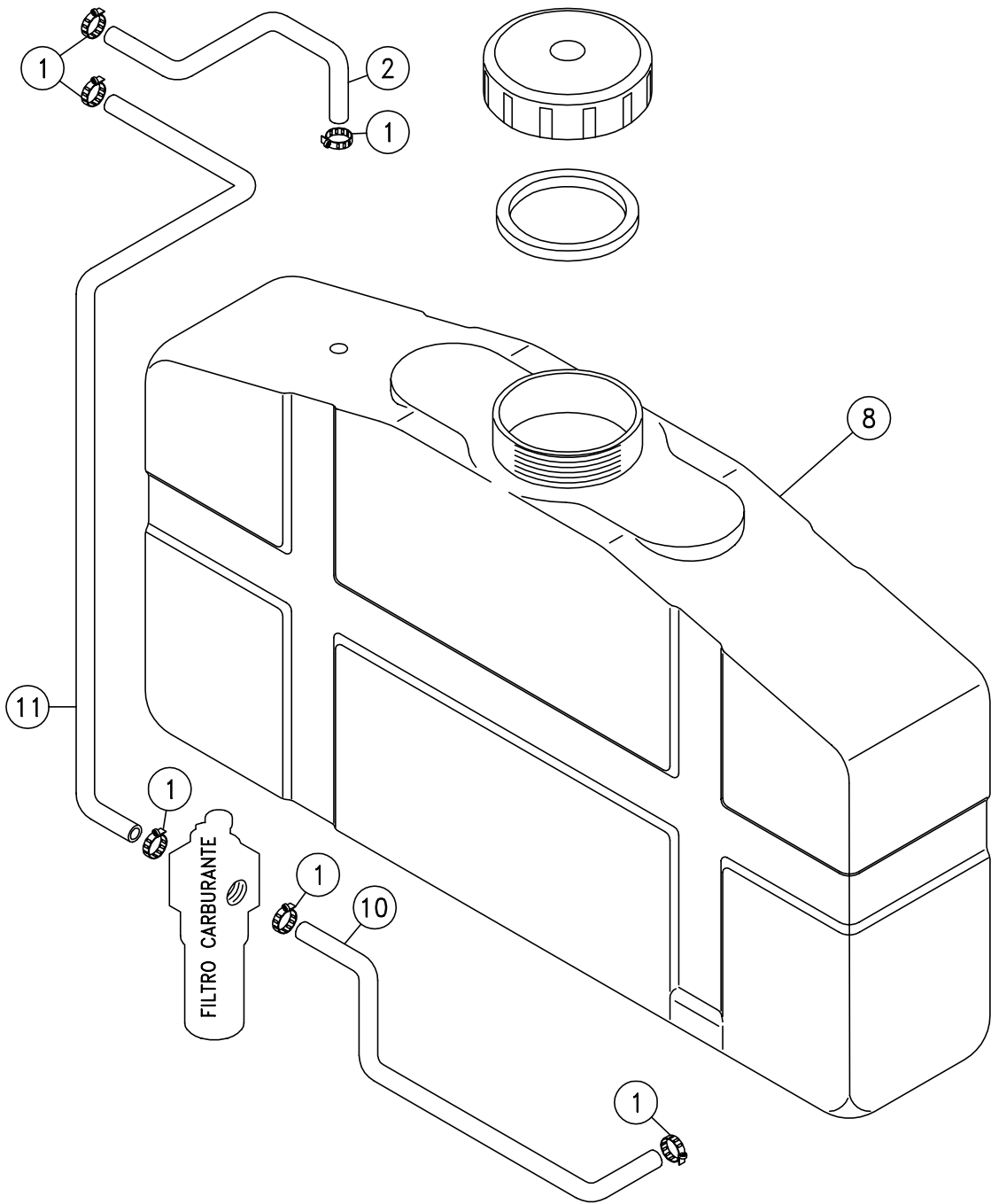

DETAILS LIST OF MDVN 36 AP

TAB. 4

POSITION	DESCRIPTION	CODE	QUANTITY
1	PIPE-TIGHTENING STRIP 8/11	149-005-S	6
2	ANTI-OIL PIPE FOR FUEL	089-120-S	1
8	GAS OIL TANK	201-024-S	1
10	ANTI-OIL PIPE FOR FUEL	089-120-S	1
11	ANTI-OIL PIPE FOR FUEL	089-120-S	1

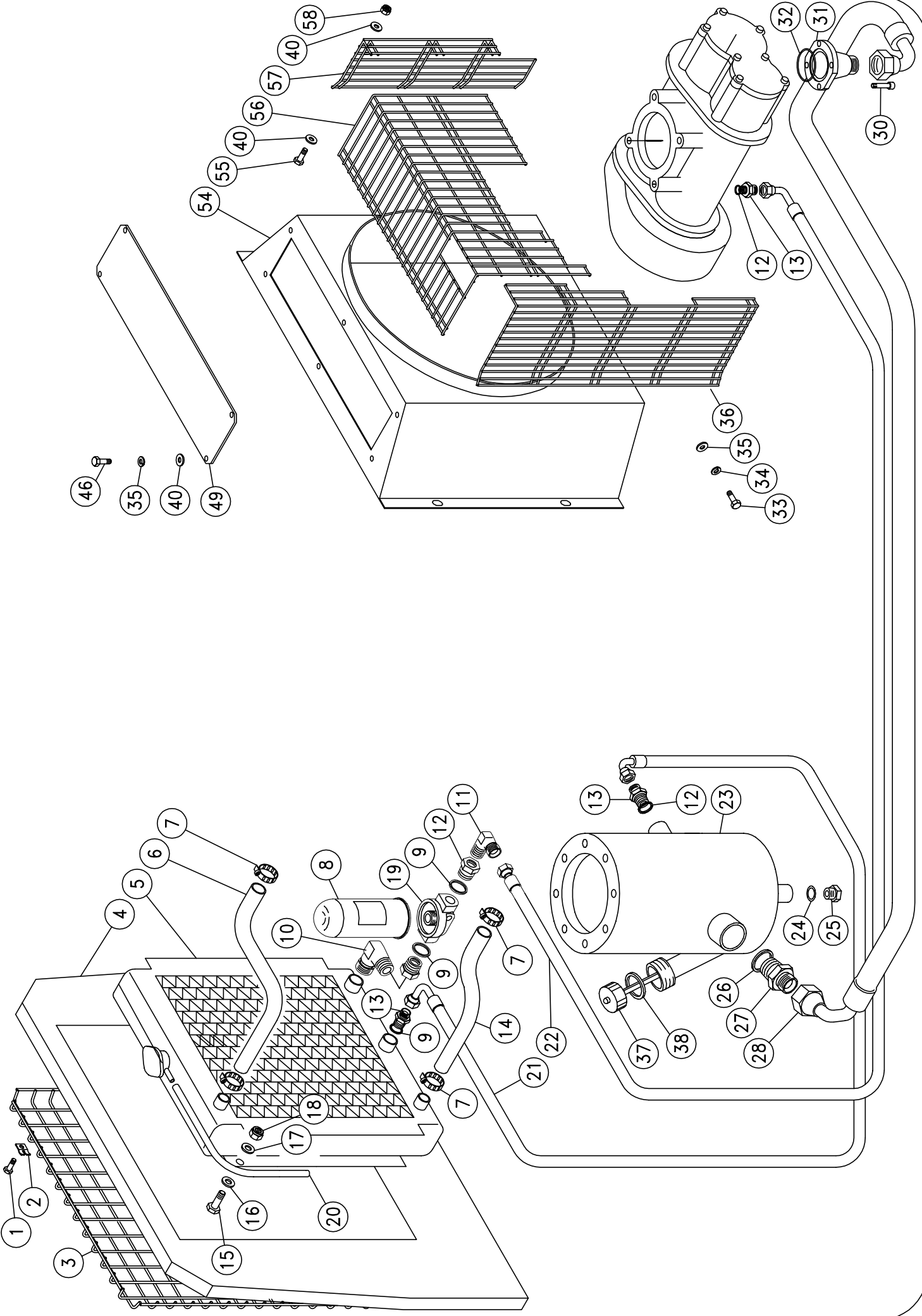

DETAILS LIST OF MDVN 36 AP

TAB. 5

POSITION	DESCRIPTION	CODE	QUANTITY
1	T.E. SCREW 6X25	132-065-S	5
2	RADIATOR PROTECTIVE GRATING FIXTURE INSERT	120-380-S	2
3	RADIATOR PROTECTIVE PANEL WITH GRATING	124-2681-S	1
4	RADIATOR SUPPORT	049-1181-S	1
5	WATER-OIL RADIATOR	011-0935-S	1
6	CALORFLEX PIPE	089-006-S	1
7	PIPE-TIGHTENING STRIP 32X50	149-130-S	4
8	OIL FILTER COMPRESSOR	099-007-S	1
9	COPPER WASHER DIAM. 26	015-015-S	1
10	90° ROTATING ¾" FITTING	148-2985-S	1
11	90° ¾" FITTING	148-287.6-S	1
12	REDUCTION ELEMENT ¾"M – ½"F	190-041-S	1
13	DOUBLE SCREW ¾" - 1/2"	187-050-S	1
14	CALORFLEX PIPE	089-006-S	1
15	T.E. SCREW 8X20	132-101-S	4
16	GROWER DIAM. 8	139-040-S	4
17	FLAT WASHER 9X24X2	015-031-S	4
18	SELF-LOCKING NUT M8	137-040-S	4
19	OIL FILTER SUPPORT	010-047-S	1
20	KRISTALL PIPE 12X8	089-090-S	1
21	OIL PIPING ¾" F90+F90 L=1280	065-687.2-S	1
22	OIL PIPING O ¾" FD+F90 L=1700	065-643.625-S	1
23	OIL SEPARATOR TANK	037-055-S	1
24	COPPER WASHER 1/2"	015-012-S	1
25	HEXAGONAL HEAD IRON CAP 1/2"	106-125-S	1
26	COPPER WASHER 1"1/2	015-019.1-S	1
27	DOUBLE SCREW 1"1/2	187-090-S	1
28	OIL PIPING 1"1/2 F90+F90 L=1080	065-495.30-S	1
30	TCEI SCREW 10X25	133-182-S	4
31	FLEX 1"1/2 ATTACHMENT FLANGE	004-340-S	1
32	SEAL OR	023-067-S	1
33	T.E. SCREW 6X20	132-063-S	1
34	GROWER DIAM. 6	139-030-S	6
35	FLAT WASHER	015-029-S	1
36	RIGHT FAN PROTECTIVE PANEL WITH GRATING	124-2935-S	1
37	OIL LEVEL ROD CAP	106-010.5-S	1
38	ROD CAP SEAL	023-026.5-S	1

ROTAIR S.p.A.

40	WASHER 6X12	015-027-S	6
46	T.E. SCREW 6X16	132-062-S	6
49	FAN COVER CLOSURE PANEL	124-2835-S	1
54	FAN COVER	001-1732-S	1
55	T.E. SCREW 6X16	132-062-S	1
56	UPPER FAN PROTECTIVE PANEL WITH GRATING	124-2933-S	1
57	LEFT FAN PROTECTIVE PANEL WITH GRATING	124-2934-S	1
58	SELF-LOCKING NUT M6	137-030-S	1

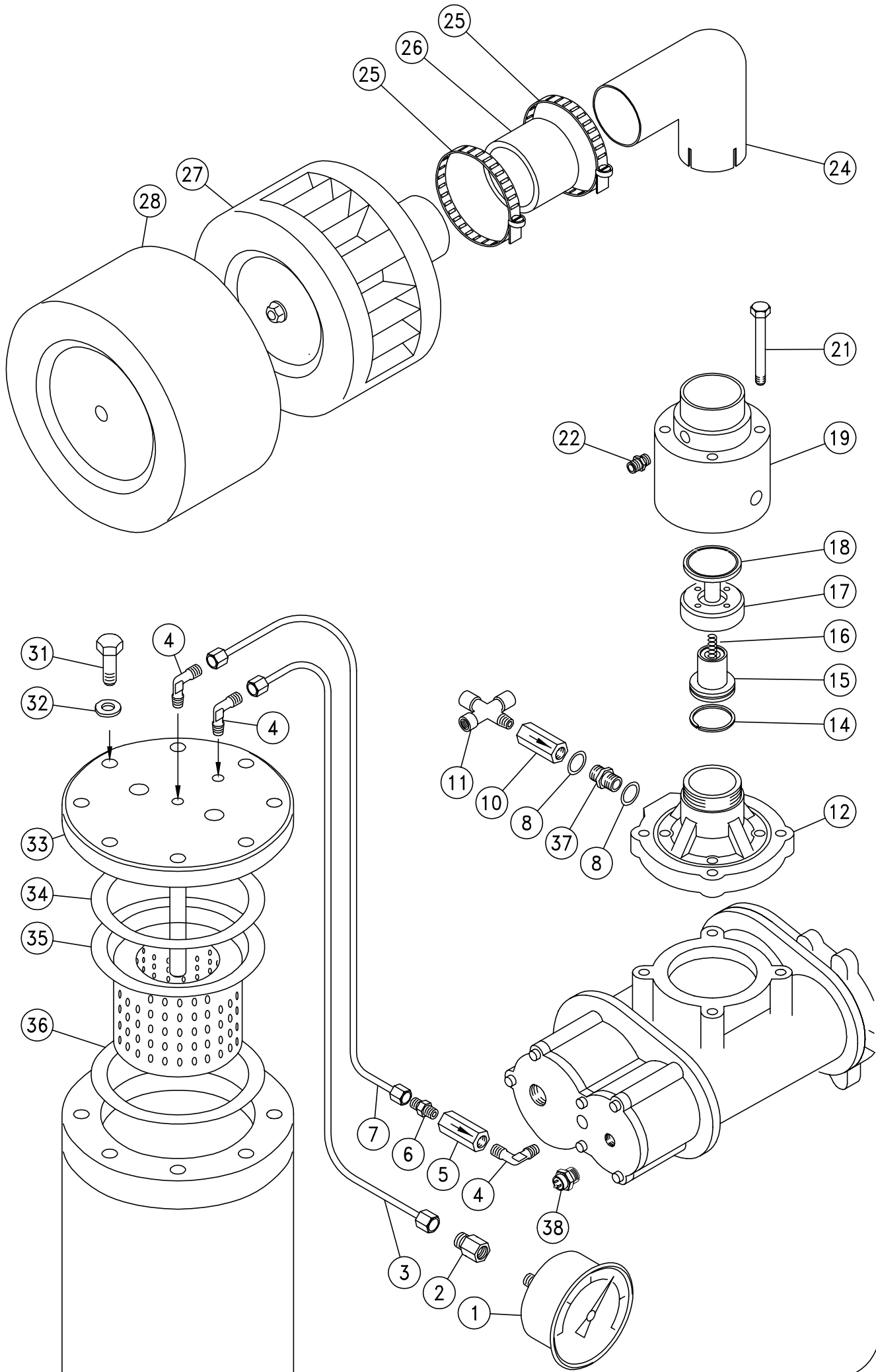

DETAILS LIST OF MDVN 36 AP

TAB. 6

POSITION	DESCRIPTION	CODE	QUANTITY
1	MANOMETER	206-010-S	1
2	SPACER	009-014-S	1
3	POLYAMIDE PIPE 6X4	089-060-S	1
4	ELBOW JOINT 1/8"	148-288-S	3
5	NON-RETURN VALVE 1/8"	033-001-S	1
6	STRAIGHT COUPLING 1/8"	148-040-S	1
7	POLYAMIDE PIPE 6X4	089-060-S	1
8	COPPER WASHER 1/4"	015-007-S	2
9	DOUBLE SCREW 1/4"	187-005-S	1
10	NON-RETURN VALVE 1/4"	033-017-S	1
11	CROSS FITTING 1M 1/4" + 3F 1/4"	148-193-S	1
12	REGULATOR BASE	034-001-S	1
14	SEGMENT	199-050-S	1
15	REGULATOR PISTON	048-009-S	1
16	REGULATOR SPRING	043-006-S	1
17	ALUMINIUM RING	194-001-S	1
18	SUCTION VALVE	033-005-S	1
19	REGULATOR BODY	053-075-S	1
21	TCEI SCREW 10X110	133-199-S	4
22	DOUBLE SCREW 1/4"	187-005-S	1
24	COMPRESSOR AIR FILTER ELBOW	111-099-S	1
25	PIPE-TIGHTENING STRIP 50/70	149-140-S	1
26	RUBBER SLEEVE	063-201-S	1
27	AIR FILTER	162-574-S	1
	SECONDARY AIR FILTER (OPTIONAL)	162-575-S	1
28	CONTAINER AIR FILTER	014-2895-S	1
31	T.E. SCREW 12X35	132-193-S	8
32	WASHER 13X27X2,5	015-047-S	8
33	OIL SEPARATOR CLOSURE FLANGE	004-119-S	1
34	SEAL	Whit 157-201-S	1
35	OIL SEPARATOR FILTER	157-201-S	1
36	SEAL	Whit 157-201-S	1
37	ROTATING FITTING	148-003.2-S	1
38	THERMO-CONTACT COMPRESSOR	103-008-S	1

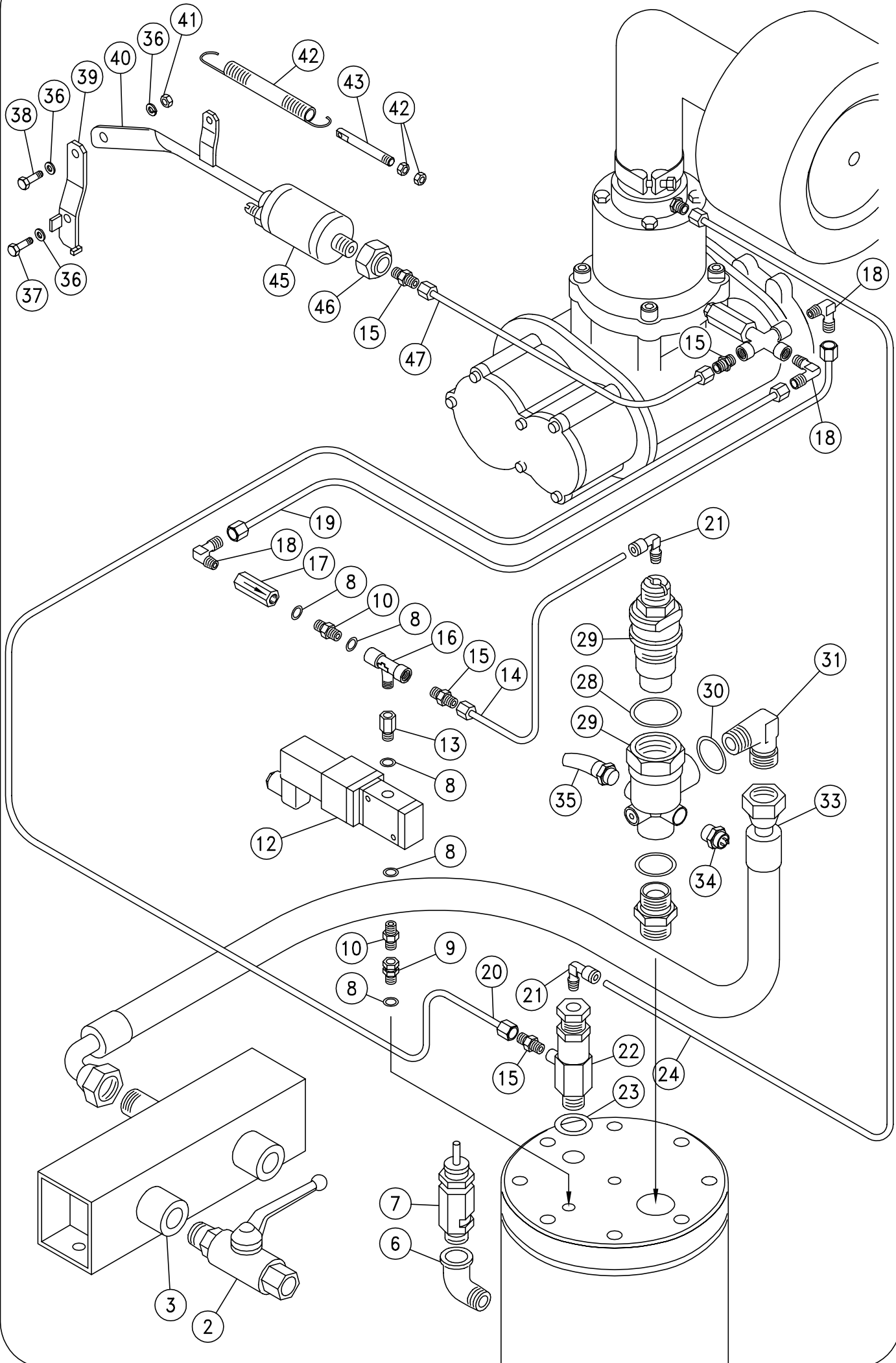

DETAILS LIST OF MDVN 36 AP

TAB. 7

POSITION	DESCRIPTION	CODE	QUANTITY
2	BALL VALVE 3/4"	152-030-S	2
3	COCK ATTACHMENT SLEEVE	063-106-S	1
6	SHORT-RADIUS ELBOW M 1/2" F 1/2"	111-030-S	1
7	SAFETY VALVE	033-051-S	1
8	COPPER WASHER 1/4"	015-007-S	5
9	ROTATING FITTING	148-003.2-S	1
10	DOUBLE SCREW 1/4"	187-005-S	1
12	SOLENOID VALVE 1/4" NA	160-120-S	1
12	12 V COIL	160-121-S	1
13	EXTENSION 1/4"	189-032-S	1
14	POLYAMIDE PIPE 8X6	089-070-S	1
15	STRAIGHT COUPLING 1/4" DIAM. 8X6	148-070-S	4
16	T-FITTING F+M+F 1/4"	148-194-S	1
17	NON-RETURN VALVE 1/4"	033-017-S	1
18	ELBOW JOINT 1/4" DIAM. 8X6	148-110-S	2
19	POLYAMIDE PIPE 8X6	089-070-S	1
20	POLYAMIDE PIPE 8X6	089-070-S	1
21	RAPID ROTARY FITTING 1/8"	148-800-S	1
22	PRESSURE REGULATING VALVE ASSEMBLY	024-032-F	1
24	POLYAMIDE PIPE 8X6	089-070-S	1
29	NON-RETURN VALVE ASSEMBLY	024-0101-F	1
30	COPPER WASHER 1"	015-010-S	1
31	90° ROTATING FITTING M+M 1"	148-2987-S	1
33	PIPING 1" FD+F90 L=1070	065-253.7-S	1
34	OIL PRESSURE SWITCH 3,5 bar	154-025-S	1
35	OIL PRESSURE SWITCH 1,4 bar	154-030-S	1
36	FLAT WASHER 6,6X18X2	015-029-S	3
37	T.E. SCREW 6X20	132-063-S	1
38	T.E. SCREW 6X16	132-062-S	1
39	ACCELERATOR LEVER	094-038-S	1
40	ACCELERATOR PISTON ROD	102-037-S	1
41	M6 HEXAGONAL NUT	135-030-S	1
42	ACCELERATOR RETURN SPRING	043-029-S	1
43	ACCELERATOR SPRING TIE ROD SCREW	092-040-S	1
44	THERMO-CONTACT	103-008-S	1
45	ACCELERATOR PISTON ASSEMBLY	024-004-F	1
46	SELF-LOCKING NUT 18X1,5	137-094-S	1
47	POLYAMIDE PIPE 8X6	089-070-S	1
48	ACCELERATOR MINIMUM REGISTER SCREW	092-007-S	1
49	M6 HEXAGONAL NUT	135-040-S	2