

DISTINTA DELLE PARTI COSTITUENTI LE POMPE ROTATIVE VOLUMETRICHE SERIE " V "
SPARE PARTS LIST FOR "V" SERIES POSITIVE-DISPLACEMENT ROTARY PUMPS
LISTE DES PIÈCES DE RECHANGE POUR POMPES ROTATIVES VOLUMÉTRIQUES SERIE " V "
ERSATZTEILLISTE FÜR SELBSTANSAUGENDE INNENZAHNRADPUMPEN SERIE " V "

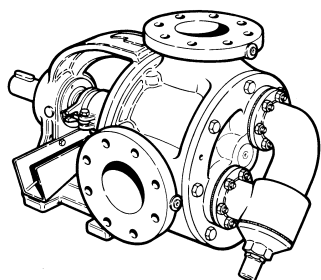

V150-2 SP Code 1001 0465

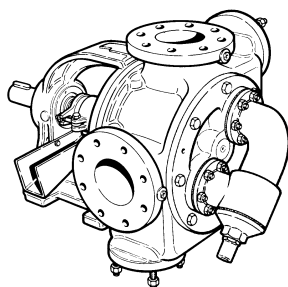

V150-2 SPHTR Code 1001 5718

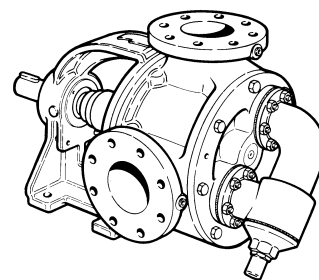

V150-2 ST4W Code 1001 0468

V150-2 ST4BS Code 1002 2240

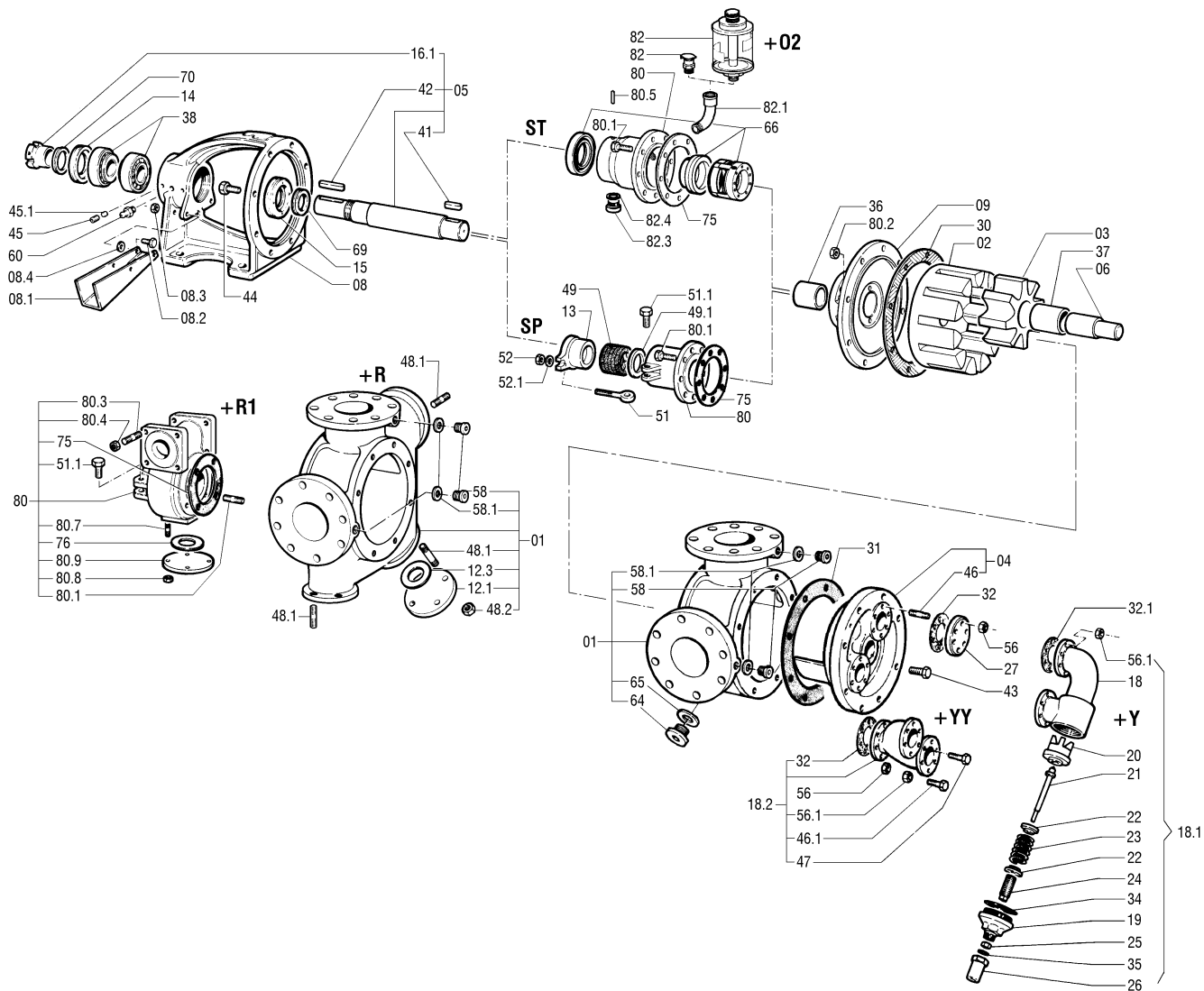

Rif. N°. Pos. Nr. Ref. no. Réf. N°.	Quant.	Denominazione	Part name	Den. Comm. Type	Mat.*	Codice Vecchio Old Part. No.	Codice Nuovo New Part. No.	V150-2SP	V150-2SPHTR	V150-2 STAW	V150-2 ST4BS
01	1	Corpo (1)	Casing (1)		GS	5319 3037	1002 2241	○		○	○
					GS	5319 3055	1000 8058	①	○	①	①
02	1	Rotore	Rotor		GS	3765 3023	1000 6600	○	○	○	○
03	1	Ruota oziosa	Idler		GS	3780 3037	1000 6759	○	○	○	
					GS		1002 2236				○
04	1	Coperchio (2)	Cover (2)		GS	5270 3025	1000 8017	○	○	○	○
05	1	Albero (3)	Shaft (3)		SH	5032 4016	1000 7621	○	○	○	
					K9	5032 5034	1000 7631				○
06	1	Perno	Idler pin	D.70	T	3540 4043	1000 5908	○		○	
					T2	3540 4044	1000 5909		○		
					K9	3540 5050	1001 7903				○
08	1	Supporto	Bearing housing		G	3872 3019	1000 6894	○	○	○	○
08.1	1	Colatoio	Drip tray		S	3435 4004	1000 5480	○	○		
08.2	2	Vite	Screw	M 8 x 20 DIN 933	S	1478 4010	1000 1937	○	○		
08.3	2	Dado	Nut	M 8 DIN 934	S	1420 4004	1000 1420	○	○		
08.4	2	Rondella	Washer	M 8 DIN 125 A	S	1450 4003	1000 1689	○	○		
09	1	Flangia supporto	Rear cover		GS	3375 3015	1000 5149	○	○		
					GS	3375 3024	1000 5155			○	○
12.1	1	Flangia	Flange	DN40 PN16 UNI 6093	S	3362 4002	1000 5133	①	○	①	①
12.3 (**)	1	Guarnizione	Gasket	50 x 88 x 2							
13	1	Premitreccia	Gland		G	3690 3010	1000 6520	○	○		
14	1	Copricuscinetto	Bearing cover		G	3287 3025	1000 4811	○		○	○
					G	3287 3031	1000 4815	①	○	①	①
15	1	Copricuscinetto	Bearing cover		G	3287 3025	1000 4811	○		○	○
					G	3287 3030	1000 4814	①	○	①	①
16.1	1	Ghiera	Sleeve	65 x 75 x 43	F	3107 4505	1000 4241	○	○	○	○
18	1	Corpo By-pass	By-pass casing		G	3240 3020	1000 4461	④	④	④	④
	2							⑤	⑤	⑤	⑤
18.1	1	By-pass	By-pass		G	5090 3034	1000 7750	④	④	④	④
	2							⑤	⑤	⑤	⑤
18.2	2	Raccordo doppio (4)	Double manifold (4)		G	5240 3027	1000 7908	⑤	⑤	⑤	⑤
19	1	Coperchio By-pass	By-pass cover		G	3240 3005	1000 4451	④	④	④	④
	2							⑤	⑤	⑤	⑤
20	1	Valvola By-pass	By-pass check valve		G	3240 3030	1000 4469	④	④	④	⑤
	2							⑤	⑤	⑤	⑤
21	1	Perno By-pass	By-pass idler pin		S	3240 4014	1000 4488	④	④	④	④
	2							⑤	⑤	⑤	⑤
22	2	Piattello By-pass	By-pass plate		S	3240 4004	1000 4480	④	④	④	④
	4							⑤	⑤	⑤	⑤
23	1	Molla By-pass	By-pass spring	D. 8 x 42 x 95 x 15,5	SHT	3495 4020	1000 5789	④	④	④	④
	2							⑤	⑤	⑤	⑤
24	1	Vite By-pass	By-pass screw		B	3240 2003	1000 4444	④	④	④	④
	2							⑤	⑤	⑤	⑤
25	1	Dado	Nut	M12 DIN 934	B	3240 2007	1000 4447	④	④	④	④
	2							⑤	⑤	⑤	⑤
26	1	Cappello By-pass	By-pass cap		A	3240 1001	1000 4440	④	④	④	④
	2							⑤	⑤	⑤	⑤
27	2	Flangia By-pass	By-pass flange		F	3362 4000	1000 5131	○	○	○	○
30 (**)	1	Guarnizione corpo	Casing gasket	350 x 433 x 0,5							
31 (**)	1	Guarnizione coperchio	Cover gasket	350 x 433 x 0,5							
32 (**)	2	Guarnizione	Gasket	85 x 149 x 0,5							
32.1	4	Guarnizione	Gasket	85 x 149 x 0,5	E3	3450 0008	1000 5496	⑤	⑤	⑤	⑤
34	1	Guarnizione	Gasket	121 x 140 x 0,5	E3	3450 0023	1000 5507	④	④	④	④
	2							⑤	⑤	⑤	⑤

VARISCO S.p.A.

35129 Padova – Z.I. Nord Terza Strada, 9

Tel. 049 82 94 111

Fax 049 82 94 373

+39 049 82 94 111

International +39 049 80 76 762



Rif. N°. Pos. Nr. Ref. no. Réf. N°.	Quant.	Denominazione	Part name	Den. Comm. Type	Mat.*	Codice Vecchio Old Part. No.	Codice Nuovo New Part. No.	V150-2SP	V150-2SPHTR	V150-2 STAW	V150-2 ST4BS
35	1 2	Guarnizione cappell.	Cap gasket	28 x 37 x 0,5	E3	3450 0013	10005499	④ ⑤	④ ⑤	④ ⑤	④ ⑤
36	1	Bronzina supporto	Bearing bush	70 x 90 x 120	AD10 GR	3120 2050 3120 3027	1000 4315 1000 4274	○	○	○	○
37	1	Bronzina ruota oziosa	Idler bush	70 x 90 x 149	AD10 GR	3120 2051 3120 0044	1000 4316 1000 4284	○	○	○	○
38	2	Cuscinetto	Ball bearing	32213	S	1418 0022	1000 1343	○	○	○	○
41	1	Linguetta	Key	18 x 11 x 80 DIN 6885A	K	1434 5016	1000 1631	○	○	○	○
42	1	Linguetta	Key	18 x 11 x 120 DIN 6885A	S	1434 4026	1000 1604	○	○	○	○
43 (*)	8	Vite	Screw	M 16 x 40 DIN 933				○	○	○	○
44 (*)	8	Vite	Screw	M 16 x 70 DIN 931				○	○	○	○
45 (*)	2	Vite	Screw	M 8 x 25 DIN 913				○	○	○	○
45.1 (*)	2	Pastiglia	Shim	D. 6 x 5				○	○	○	○
46 (*)	12	Prigioniero	Stud	M 10 x 25 DIN 938				○	○	○	○
46.1	10	Vite	Screw	M 10 x 40 DIN 931	S	1478 4028	1000 1951	⑤	⑤	⑤	⑤
47	2	Vite	Screw	M 10 x 25 DIN 933	S	1478 4025	1000 1948	⑤	⑤	⑤	⑤
48.1	12	Prigioniero	Stud	M 16 x 40 DIN 938	S	1468 4017	1000 1831	①	○	①	①
48.2	12	Dado	Nut	M 16 DIN 934	S	1420 4009	1000 1425	①	○	①	①
49	1	Baderna	Packing	70 x 95 x 12,5 x 5 70 x 95 x 12,5 UP3075	TE	5060 0044 5060 0045		○ ①	○		
49.1	1	Anello	Ring		K	3045 5020	1000 4093	○	○		
51	2	Tirante	Eyebolt	M 10 x 60 DIN 444B	H	1466 5002	1000 1815	○	○		
51.1	2	Vite	Screw	M 10 x 35 DIN 933 M 10 x 35 DIN 933	S S	1478 4027 1478 4027	1000 1950 1000 1950	○ ②	○ ②		
52	2	Dado	Nut	M 10 DIN 934	S	1420 4005	1000 1421	○	○		
52.1	2	Rondella	Washer	M 10 DIN 125A	S	1450 4005	1000 1691	○	○		
56 (*)	12	Dado	Nut	M 10 DIN 934				○	○	○	○
56.1	12 24	Dado	Nut	M 10 DIN 934 M 10 DIN 934	S S	1420 4005 1420 4005	1000 1421 1000 1421	○ ⑤	○ ⑤	○ ⑤	○ ⑤
58 (*)	2	Tappo	Plug	R¼" DIN 908				○	○	○	○
58.1 (**)	2	Guarnizione	Gasket	¼"							
60 (*)	1	Ingrassatore	Grease nipple	¼"				○	○	○	○
64 (*)	2	Tappo	Plug	½" DIN 908				○		○	○
65 (**)	2	Guarnizione	Gasket	½"							
66	1 1	Tenuta completa	Mechanical seal	N 70 WCT - FL N 70 GCT - FL		5919 4015 5919 4016	1000 8954 1000 8955			○	○
69	1	Paraolio	Oil seal			1408 6009	1000 1298	○		○	○
70	1	Paraolio	Oil seal			1408 6010	1000 1299	○		○	○
75 (**)	1	Guarnizione	Gasket	126 x 164 x 0,5							
76	1	Guarnizione	Gasket	28 x 60 x 2	E3	3450 0258	1000 5595	②	②		
80	1 1	Portabaderna	Stuffing box		G GS	3615 3014 5615 3021	1000 6163 1002 2327	○ ②	○ ②		
	1	Portatenuta	Seal box		G	1001 6891	1001 6891			○	○
80.1	8	Vite	Screw	M 8 x 35 DIN 933	S	1478 4013	1000 1940	○	○		
		Prigioniero	Stud	M 8 x 25 DIN 938 M 8 x 25 DIN 933	S S	1468 4003 1478 4011	1000 1822 1000 1938	② ○	② ○		○
80.2	8	Dado	Nut	M 8 DIN 934	S	1420 4004	1000 1420	○	○	○	○
80.3	8	Prigioniero	Stud	M 16 x 40 DIN 938	S	1468 4017	1000 1831	②	②		
80.4	8	Dado	Nut	M 16 DIN 934	S	1420 4009	1000 1425	②	②		
80.5	1	Spina	Spring pin	4 x 20	H	1463 5007	1000 1784			○	○
80.7	4	Prigioniero	Stud	M 12 x 30 DIN 938	S	1468 4010	1000 1827	②	②		
80.8	4	Dado	Nut	M 12 DIN 934	S	1420 4006	1000 1422	②	②		
80.9	1	Flangia	Flange	DN20 PN16 UNI 6093	S	3362 4001	1000 5132	②	②		

VARISCO S.p.A.

35129 Padova - Z.I. Nord Terza Strada, 9

Tel. 049 82 94 111

Fax 049 82 94 373

+39 049 82 94 111
International +39 049 80 76 762



Rif. N°. Pos. Nr. Ref. no. Réf. N°.	Quant.	Denominazione	Part name	Den. Comm. Type	Mat.*	Codice Vecchio Old Part. No.	Codice Nuovo New Part. No.	V150-2SP	V150-2SPHTR	V150-2 ST4W	V150-2 ST4BS
82	1	Oliatore	Oil lubricator	R ¼" KLG 4 R ¼"	S	1444 0053 1444 0055	1000 1671 1000 1672			○ ⊙	○ ⊙
82.1	1	Curva	Elbow	R ¼"	G	1601 3002	1000 2292			○	
82.3	3	Tappo	Plug	R ¼" DIN 908 R ¼" DIN 908	S K	1671 4002 1671 5002	1000 2410 1000 2414			○ ○	○ ○
82.4	3	Guarnizione	Gasket	¼"	D	3450 0600	1000 5657			○	○
(*)		Serie viterie	Set of screws				1001 5179 1001 5181	○ ⊙		○ ⊙	○ ⊙
(**)		Serie guarnizioni	Set of gasket				1001 4969 1001 4970	○ ⊙	○ ○	○ ⊙	○ ⊙

Note:

- 1) Completo di tappi (58), guarnizioni, (12.3, 58.1), prigionieri (48.1), flangia (12.1) e dadi (48.2)
- 2) Completo di prigionieri (46)
- 3) Completo di linguette (41, 42), ghiera (16.1).
- 4) Completo di viti (47, 46.1), dado (56.1) e guarnizione (32).

- ① + R Corpo riscaldato
- ② + R1 Tenuta riscaldata
- ③ + O2 Oliatore da 140 ml in vetro
- ④ + Y Con by-pass
- ⑤ + YY Con doppio by-pass

* Materiali di costruzione

- A = Alluminio
- AD10 = Bronzo AD10
- B = Bronzo
- D = Guarnital o fibra
- E3 = Centellen VS 3820
- F = Ferro
- G = Ghisa
- GR = Grafite
- GS = Ghisa sferoidale
- H = Acciaio inox AISI 304
- K = Acciaio inox AISI 316
- K9 = Acciaio inox AISI 329
- S = Acciaio
- SH = Acciaio trattato
- T = Acciaio cementato
- T2 = Acciaio K110
- TE = Teflon

Ordinare il materiale indicando sempre la quantità, la denominazione, il codice del pezzo, il tipo ed il numero della pompa.

Notes:

- 1) Complete with plugs (58), gaskets (12.3, 58.1), studs (48.1), flange (12.1) and nuts (48.2)
- 2) Complete with studs (46)
- 3) Complete with keys (41, 42), sleeve (16.1).
- 4) Complete with screw (47,46.1), nuts(56.1) and gaskets (32).

- ① + R Heating jacket on casing
- ② + R1 Heating jacket on stuffing box
- ③ + O2 With 140 ml glass oil lubricator
- ④ + Y With by-pass
- ⑤ + YY With double by-pass

* Construction materials

- A = Aluminium
- AD10 = AD10 Bronze
- B = Bronze
- D = Guarnital or fiber
- E3 = Centellen VS 3820
- F = Iron
- G = Cast iron
- GR = Graphite
- GS = Ductile cast iron
- H = AISI 304 stainless steel
- K = AISI 316 stainless steel
- K9 = AISI 329 stainless steel
- S = Steel
- SH = Hardened steel
- T = Case hardened steel
- T2 = K110 steel
- TE = Teflon

When ordering spares always indicate type and serial number of pump, quantity, part name, and number.

VARISCO S.p.A.

35129 Padova – Z.I. Nord Terza Strada, 9

Tel. 049 82 94 111

Fax 049 82 94 373

+39 049 82 94 111
International +39 049 80 76 762

