

**DISTINTA DELLE PARTI COSTITUENTI LE POMPE ROTATIVE VOLUMETRICHE SERIE "V"**  
**SPARE PARTS LIST FOR "V" SERIES POSITIVE-DISPLACEMENT ROTARY PUMPS**  
**LISTE DES PIÈCES DE RECHANGE POUR POMPES ROTATIVES VOLUMÉTRIQUES SERIE "V"**  
**ERSATZTEILLISTE FÜR SELBSTANSAUGENDE INNENZAHNRADPUMPEN SERIE "V"**

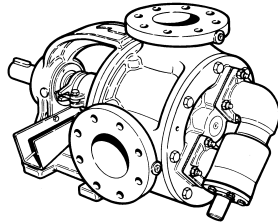

V 90-2 SPK Code 1001 0388

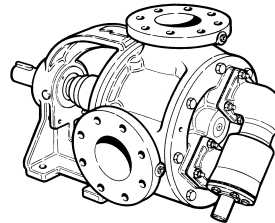

V 90-2 ST4K Code 1001 9439

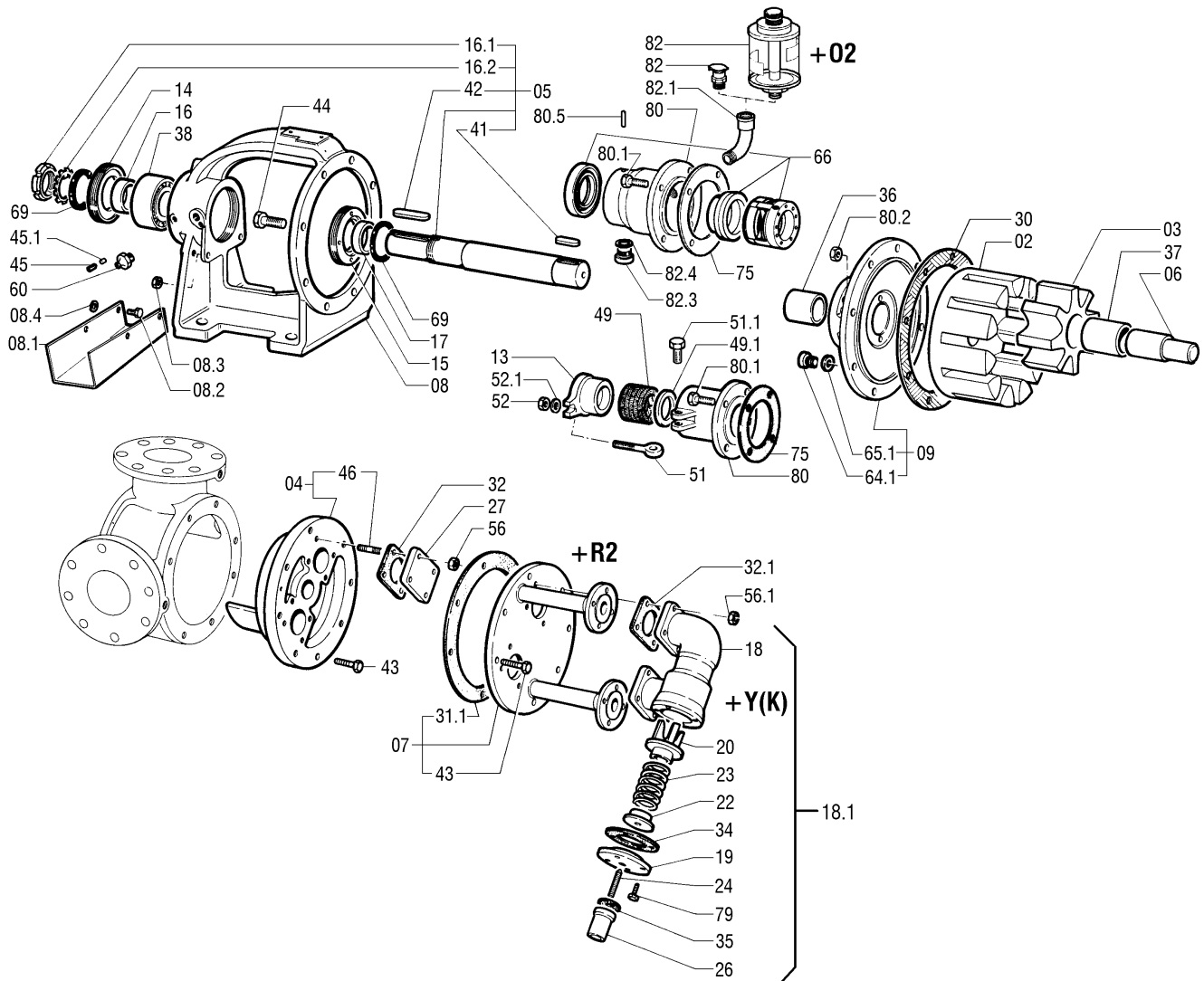

Rif. N°. Pos. Nr. Ref. no. Réf. N°.	Quant.	Denominazione	Part name	Den. Comm. Type	Mat.*	Codice Vecchio Old Part No.	Codice Nuovo New Part No.	V90-2 SPK	V90-2 ST4K
01	1	Corpo (1)	Casing (1)		K	5319 5008	1000 8067	○	○
02	1	Rotore	Rotor		K	3765 5006	1000 6666	○	○
03	1	Ruota oziosa	Idler		K	3780 5008	1000 6821	○	○
04	1	Coperchio (2)	Cover (2)		K	5270 5007	1001 7000	○	○
					K		1001 9551	①	①
					K		1001 9551	④	④
05	1	Albero (3)	Shaft (3)		K5	5032 5033	1000 7630	○	○
06	1	Perno	Idler pin		K9	3540 5062	1000 5947	○	○
07	1	Camera di prerisc. (4)	Heating jacket (4)		S+K	5135 4009	1001 9368	①	①
						5135 4011	1001 9369	④	④
08	1	Supporto	Bearing housing		G	3872 3016	1000 6892	○	○
08.1	1	Colatoio	Drip tray		K	3435 5003	1000 5485	○	
08.2	2	Vite	Screw	M 8 x 20 DIN 933	K	1478 5008	1000 2027	○	
08.3	2	Dado	Nut	M 8 DIN 934	K	1420 5004	1000 1435	○	
08.4	2	Rondella	Washer	M 8 DIN 125 A	H	1450 5016	1000 1718	○	
09	1	Flangia supporto	Rear cover		K	3375 5016	1000 5175	○	
						3375 5028	1000 5180		○
13	1	Premitreccia	Gland		K	3690 5006	1000 6527	○	
14	1	Copricuscinetto	Bearing cover		G	3287 3020	1000 4807	○	○
15	1	Copricuscinetto	Bearing cover		G	3287 3022	1000 4809	○	○
16	1	Ghiera	Sleeve	50 x 60 x 16	S	3107 4510	1000 4246	○	○
16.1	1	Ghiera	Sleeve	M 50 x 1,5	S	1430 4007	1000 1576	○	○
16.2	1	Rondella	Washer	MB10 UNI 3073 D.50	S	1452 4003	1000 1722	○	○
17	1	Ghiera	Sleeve	50 x 60 x 16	S	3107 4510	1000 4246	○	○
18	1	Corpo By-pass	By-pass casing		K	3240 5048	1000 4524	②	②
18.1	1	By-pass	By-pass		K	50905017	1000 7763	②	②
19	1	Coperchio By-pass	By-pass cover		K	3240 5053	1000 4528	②	②
20	1	Valvola By-pass	By-pass check valve		K	3240 5051	1000 4526	②	②
22	1	Piattello By-pass	By-pass plate		K	3240 5056	1000 4529	②	②
23	1	Molla By-pass	By-pass spring	D. 8 x 42 x 95 x 15,5	K	3495 5006	1000 5798	②	②
24	1	Vite By-pass	By-pass screw	M 12 x 50 DIN 914	K	3240 5032	1000 4513	②	②
26	1	Cappello By-pass	By-pass cap		K	3240 5000	1000 4493	②	②
27	2	Flangia By-pass	By-pass flange		K	3362 5002	1000 5138	○	○
30 (**)	1	Guarnizione corpo	Casing gasket	281 x 359 x 0,5					
31 (**)	1	Guarnizione coperchio	Cover gasket	281 x 359 x 0,5					
31.1	1	Guarnizione coperchio	Cover gasket		E3	3450 0054	1000 5516	①	①
					E3	3450 0055	1001 9371	④	④
32 (**)	2	Guarnizione	Gasket						
34	1	Guarnizione	Gasket	87 x 123 x 0,5	E3	3450 0010	1000 5520	②	②
35	1	Guarnizione cappell.	Cap gasket	13 x 24 x 0,5	E3	3450 0029	1000 5512	②	②
36	1	Bronzina supporto	Bearing bush	55 x 70 x 80	GR	3120 0026	1000 4273	○	○
37	1	Bronzina ruota oziosa	Idler bush	60 x 75 x 75	GR	3120 0016	1000 4266	○	○
38	1	Cuscinetto	Ball bearing	3310 HT	S	1418 0029	1000 1388	○	○
41	1	Linguetta	Key	14 x 9 x 40 DIN 6885A	K	1434 5012	1000 1628	○	○
42	1	Linguetta	Key	14 x 9 x 100 DIN 6885A	S	1434 4023	1000 1601	○	○
43 (*)	8	Vite	Screw	M 16 x 40 DIN 933	K			○	○
	8	Prigioniero	Stud	M 16 x 90	K	3975 5030	1001 9372	①	①
					K	3975 5030	1001 9372	④	④
44 (*)	8	Vite	Screw	M 16 x 55 DIN 933	K			○	○
45 (*)	2	Vite	Screw	M 6 x 16 DIN 913	S			○	○
45.1 (*)	2	Pastiglia	Shim	D. 4.8 x 3	R			○	○
46 (*)	8	Prigioniero	Stud	M 10 x 30 DIN 938	K			○	○
				M 10 x 35 DIN 933	K	1468 5004	1000 1846	①	①
				M 10 x 45 DIN 938	K	1468 5005	1000 1847	④	④
49	1	Baderna	Packing	55 x 75 x 10 x 5	TE	5060 0036	1000 7648	○	
49.1	1	Anello	Ring		K	3045 5019	1000 4092	○	
51	2	Tirante	Eyebolt	M 10 x 60 DIN 444B	H	1466 5002	1000 1815	○	

VARISCO S.p.A.

35129 Padova – Z.I. Nord Terza Strada, 9

Tel. 049 82 94 111

+39 049 82 94 111

Fax 049 82 94 373

International +39 049 80 76 762



Rif. N°. Pos. Nr. Ref. no. Réf. N°.	Quant.	Denominazione	Part name	Den. Comm. Type	Mat.*	Codice Vecchio Old Part No.	Codice Nuovo New Part No.	V90-2 SPK	V90-2 ST4K
51.1	2	Vite	Screw	M 10 x 30 DIN 933	K	1478 5027	1000 2044	○	
52	2	Dado	Nut	M 10 DIN 934	K	1420 5006	1000 1437	○	
52.1	2	Rondella	Washer	M 10 DIN 125A	H	1450 5002	1000 1705	○	
56 (*)	8	Dado	Nut	M 10 DIN 934	K			○	○
58 (*)	2	Tappo	Plug	R ¼" DIN 908	K			○	○
58.1 (**)	2	Guarnizione	Gasket	¼"					
60 (*)	1	Ingrassatore	Grease nipple	¼"	S			○	○
64 (*)	2	Tappo	Plug	R ½" DIN 908	K			○	○
64.1 (*)	1	Tappo	Plug	R ½" DIN 908	K			○	○
65 (**)	2	Guarnizione	Gasket	½"					
65.1 (**)	1	Guarnizione	Gasket	½"					
66	1	Tenuta completa	Mechanical seal	N 55 GCT - FL		5919 4011	1000 8951		○
69	2	Paraolio	Oil seal	V 60 S		1408 6008	1000 1297	○	○
75 (**)	1	Guarnizione	Gasket	106 x 154 x 0,5					
79	5	Vite	Screw	M 8 x 20 DIN 933	K	1478 5008	1000 2027	②	②
80	1	Portabaderna	Stuffing box		K	3615 5007	1000 6204	○	
		Portatenuta	Seal box		K	3615 5311	1000 6223		○
80.1	4	Vite	Screw	M 10 x 35 DIN 933	K	1478 5029	1000 2045	○	○
80.2	4	Dado	Nut	M 10 DIN 934	K	1420 5006	1000 1437	○	○
80.5	1	Spina	Spring pin	4 x 20	H	1463 5007	1000 1784		○
82	1	Oliatore	Oil lubricator		S	1444 0053	1000 1671		○
						1444 0055	1000 1672		③
82.1	1	Curva	Elbow	R ¼"	G	1601 3002	1000 2292		○
82.3	3	Tappo	Plug	R ¼" DIN 908	K	1671 5002	1000 2414		○
82.4	3	Guarnizione	Gasket	¼"	D	3450 0600	1000 5657		○
(*)		Serie viterie	Set of screws				1001 5177	○	○
(**)		Serie guarnizioni	Set of gaskets				1001 4967	○	○

**Note:**

- 1) Completo di tappi e guarnizioni (64, 65).
- 2) Completo di prigionieri (46).
- 3) Completo di linguette (41, 42), ghiera (16.1) e rondella
- 4) Completo di viti (43) e guarnizione (31.1).

- ① +R2 Coperchio riscaldato
- ② +Y Con by-pass
- ③ +O2 Oliatore da 140 ml in vetro
- ④ +R2Y Con coperchio riscaldato e by-pass.

\* Materiali di costruzione

D	= Guarnital o fibra
E3	= Centellen VS 3820
G	= Ghisa
GR	= Grafite
H	= Acciaio inox AISI 304
K	= Acciaio inox AISI 316
K5	= Acciaio inox SAF 2205
K9	= Acciaio inox AISI 329
R	= Rame
S	= Acciaio
TE	= Teflon

Ordinare il materiale indicando sempre la quantità, la denominazione, il codice del pezzo, il tipo ed il numero della pompa.

**Notes:**

- 1) Complete with plugs and gaskets (64, 65).
- 2) Complete with studs (46).
- 3) Complete with keys (41, 42), sleeve (16.1) and washer
- 4) Complete with screws (43) and gasket (31.1).

- ① +R2 Heating jacket on cover
- ② +Y With by-pass
- ③ +O2 With 140 ml glass oil lubricator
- ④ +R2Y Con heating jacket on cover and by-pass.

\* Construction materials

D	= Guarnital or fiber
E3	= Centellen VS 3820
G	= Cast iron
GR	= Graphite
H	= AISI 304 stainless steel
K	= AISI 316 stainless steel
K5	= SAF 2205 stainless steel
K9	= AISI 329 stainless steel
R	= Copper
S	= Steel
TE	= Teflon

When ordering spares always indicate type and serial number of pump, quantity, part name, and number.

VARISCO S.p.A.

35129 Padova – Z.I. Nord Terza Strada, 9

Tel. 049 82 94 111

+39 049 82 94 111

Fax 049 82 94 373

International +39 049 80 76 762



**VARISCO S.p.A.**  
35129 Padova – Z.I. Nord Terza Strada, 9  
Tel. 049 82 94 111 +39 049 82 94 111  
Fax 049 82 94 373 International +39 049 80 76 762

